

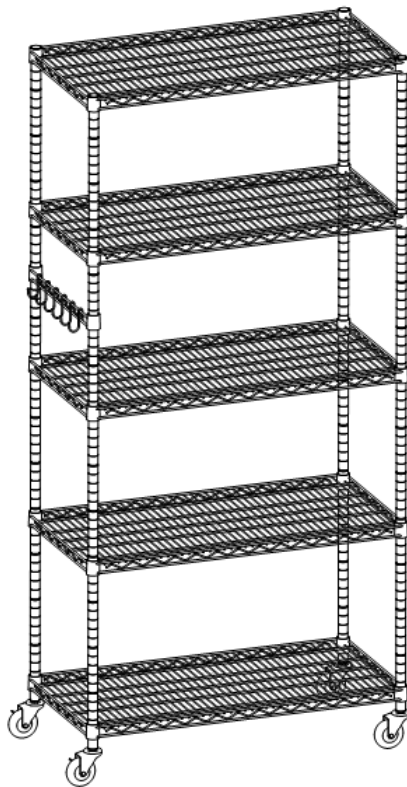

## OWNER'S MANUAL



**TRINITY 5-TIER NSF 36" x 18" x 72"  
WIRE SHELVING RACK w/WHEELS  
Model # TBFZ-0906 / TBFPBK-0906**



**Important / Important / Importante**

FOR QUICK & EASY 3D ASSEMBLY INSTRUCTIONS

POUR DES DIRECTIVES D'ASSEMBLAGE 3D RAPIDES ET FACILES

PARA INSTRUCCIONES DE ENSAMBLAJE RÁPIDAS Y SENCILLAS EN 3D

**BILT.**<sup>®</sup>

Intelligent Instructions  
Directives intelligentes  
Instrucciones Inteligentes



DOWNLOAD THE FREE APP | TÉLÉCHARGER L'APPLICATION GRATUITE | DESCARGUE LA APLICACIÓN GRATUITA

# PARTS LIST

Your TRINITY 5-Tier NSF Wire Shelving Rack w/Wheels should include the following parts. Please inspect box contents to ensure you have received all components.

If you are missing any parts, need assistance with assembly or have questions, please contact TRINITY Customer Service: 800.985.5506 or [customerservice@trinityii.com](mailto:customerservice@trinityii.com). Parts can also be requested online via "Contact Us" section at [www.trinityii.com](http://www.trinityii.com).

You will NOT need additional tools for assembly.

**A**



**BOTTOM POLE (4)**  
Insert (4)  
pre-installed

**B**



**TOP POLE (4)**  
End Cap (4) and  
Pole Connector  
pre-installed

**C**



**SHELF (5)**

**D**



**SLIP SLEEVE  
(44) + (4) extra**

**E**



**CASTER (w/wrench)  
(2 locking, 2 non-locking)**  
For mobile option

**F**



**FEET LEVELER (4)**  
For stationary option

**G**



**SIDEBAR (1)**  
(Accessory)

**H**



**"S" HOOK (6)**  
(Accessory)



*Note: The black circular plastic spacers in between Shelves are used only for packaging purposes. They are NOT needed. Please discard.*

# ASSEMBLY INSTRUCTIONS

## STEP 1

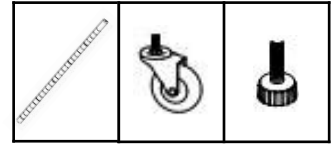

A (4)

E (4)

F (4)

### Stationary Option

Screw each FEET LEVELER (F) into bottom of each BOTTOM POLE (A). Turn clockwise to screw in place.

### Mobile Option

Screw each CASTER (E) into bottom of each BOTTOM POLE (A). Turn clockwise to screw in place. Make sure locking casters are on the same side.

**Use provided caster wrench to tighten completely.**  
**Failure to do as instructed could result in caster stem breaking.**

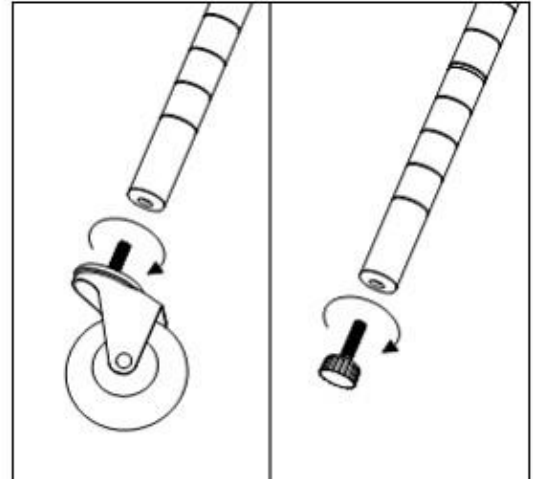

## STEP 2

For easiest assembly, do not attach TOP POLES (B) and BOTTOM POLES (A) until instructed. Once connected, these will be posts for the rack.

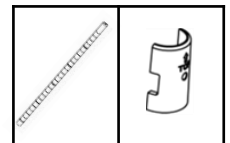

A (4)

D (8)

Note that POLES (A+B) have slight horizontal line indentations at 1" intervals. Each SLIP SLEEVE (D) has raised horizontal lines inside designed to lock them in place on POLES (A+B).

On BOTTOM POLE (A), place one pair of SLIP SLEEVES (D) at desired height **no higher than** 3rd indentation from bottom. Please make sure arrow faces up and word "TOP" is right side up.

Slide pair of SLIP SLEEVES (D) until you hear a click to confirm the pair is locked onto BOTTOM POLE (A). Do this for each BOTTOM POLE (A) and make sure height is identical for each BOTTOM POLE (A). Do NOT place more than one pair on each pole at a time.

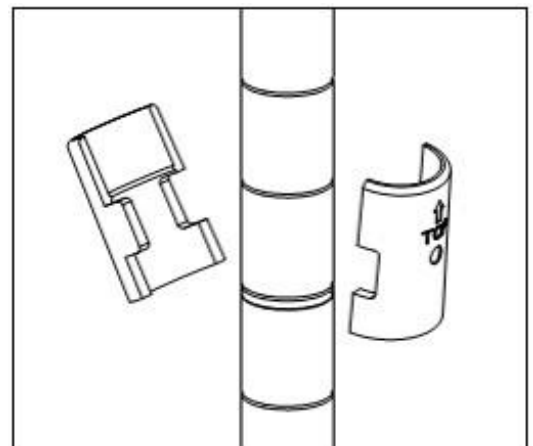

*Note: There will be a very small gap in-between two locked SLIP SLEEVES (D)—this is normal.*

# ASSEMBLY INSTRUCTIONS

## STEP 3

Place SHELF (C) on its side and slide each BOTTOM POLE (A) through each corner cylinder on SHELF (C). Make sure SHELF (C) corner cylinders are positioned over SLIP SLEEVES (D).



C (1)

Stand the unit upright.

*Note:*

- Level side of SHELF (C) is TOP side (TRINITY logo on corner cylinders should be right-side up.)
- Use a rubber mallet, if needed, to secure SHELF (C).
- For convenience, place BOTTOM POLES (A) with Locking Casters on long side of shelf if rack will be pushed against a wall, OR, if rack is frequently rolled around like a cart, place BOTTOM POLES (A) with Locking Casters on the side being pushed or pulled.

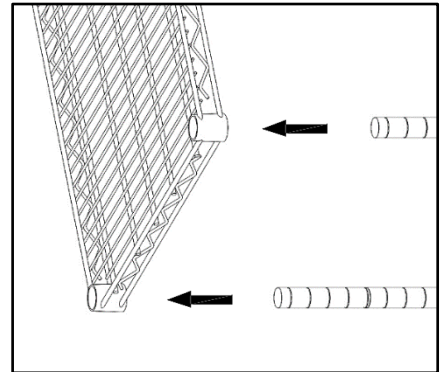

## STEP 4

On BOTTOM POLE (A), place 1 pair of SLIP SLEEVES (D) at desired height between SHELVES (C). Make sure arrow faces up and word "TOP" is right side up. Do this for each BOTTOM POLE (A), and make sure height is identical for each BOTTOM POLE (A).

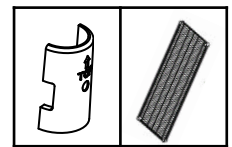

D (8)

C (1)

Lower SHELF (C) over each BOTTOM POLE (A) so corner cylinders of SHELF (C) are positioned over SLIP SLEEVES (D).

*Note:* Use a rubber mallet, if needed, to secure SHELF (C).

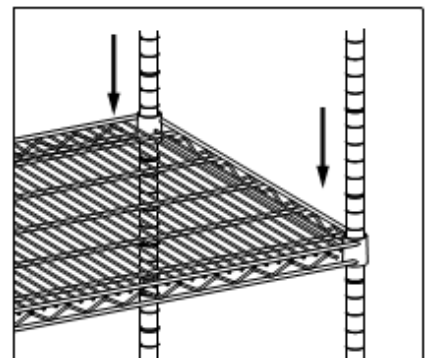

# ASSEMBLY INSTRUCTIONS

## STEP 5

Screw TOP POLE (B) into BOTTOM POLE (A).

Repeat for each remaining TOP POLE (B).

*Note: The top of each TOP POLE (B) is indicated by a BLACK END CAP.*

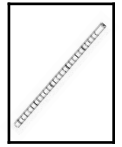

B (4)

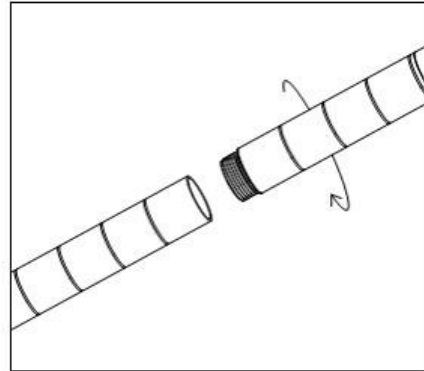

## STEP 6

Decide on where to place sidebar and hooks, attach 2 pairs of SLIP SLEEVES (D) at desired level on 2 POLES (A+B). Make sure that heights are identical for both POLES (A+B).

Slide in SIDEBAR (G) so that corner cylinders of SIDEBAR (G) are positioned over SLIP SLEEVES (D). Attach "S" HOOKS (H) either to SIDEBAR (G) or anywhere on sides of SHELF (C).

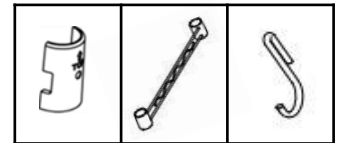

D (4)

G (1)

H (6)

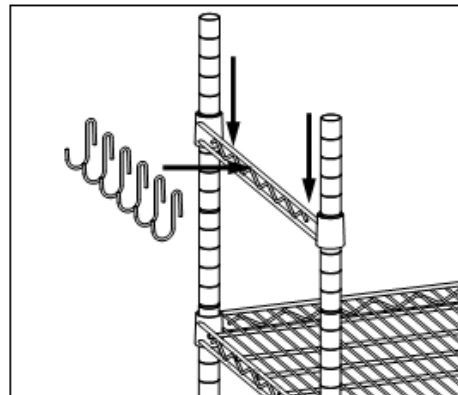

# ASSEMBLY INSTRUCTIONS

## STEP 7

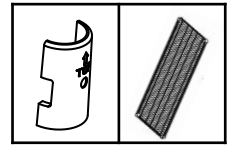

Repeat Step 4 to install other SHELVES (C) as desired.

*Note:*

- Use a rubber mallet, if needed, to secure SHELVES (C).
- For stationary option, after assembly, adjust FEET LEVELERS (F) as needed to ensure shelving rack is level.

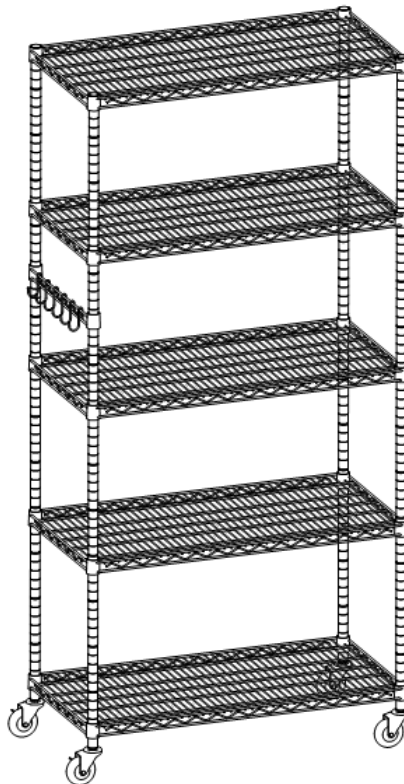
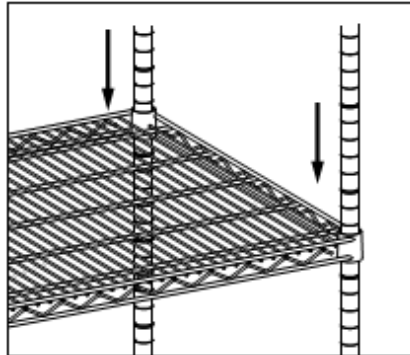

# SERVICE PARTS LIST – TBFZ-0906 Chrome Color

TRINITY Customer Service provides the following replacement parts:

Part Number	Description	Part Number	Description
1) ZSV-03-007-3618	Shelf	7) XBK-98-003-2538	Feet Leveler
2) XBK-01-011-2543	Slip Sleeve	8) XXX-97-002-0001	Wrench
3) ZSV-04-006-3600	Top Pole	9) ZSV-99-008-4010	Locking Caster
4) ZSV-01-013-2523	Pole Connector	10) ZSV-02-008-0001	"S" Hook
5) ZSV-04-008-3600	Bottom Pole	11) ZSV-02-007-0006	Sidebar
6) ZSV-99-007-4010	Non-locking Caster	12) XBK-23-004-2517	End Cap

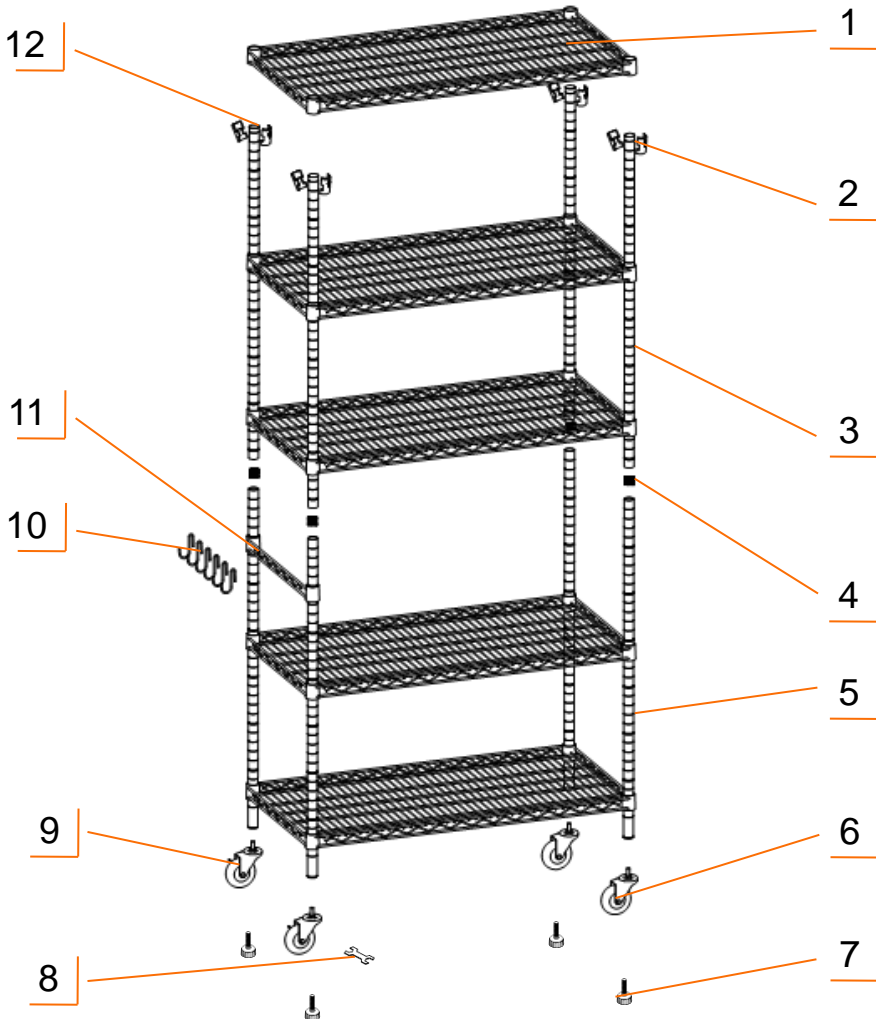



# SERVICE PARTS LIST – TBFPBK-0906 Black Color

TRINITY Customer Service provides the following replacement parts:

Part Number	Description	Part Number	Description
1) PBK-03-007-3618	Shelf	7) XBK-98-003-2538	Feet Leveler
2) XBK-01-012-2543	Slip Sleeve	8) XXX-97-002-0001	Wrench
3) PBK-04-006-3600	Top Pole	9) ZSV-99-008-4010	Locking Caster
4) ZSV-01-013-2523	Pole Connector	10) PBK-02-008-0001	"S" Hook
5) PBK-04-008-3600	Bottom Pole	11) PBK-02-007-0006	Sidebar
6) ZSV-99-007-4010	Non-locking Caster	12) XBK-23-004-2517	End Cap

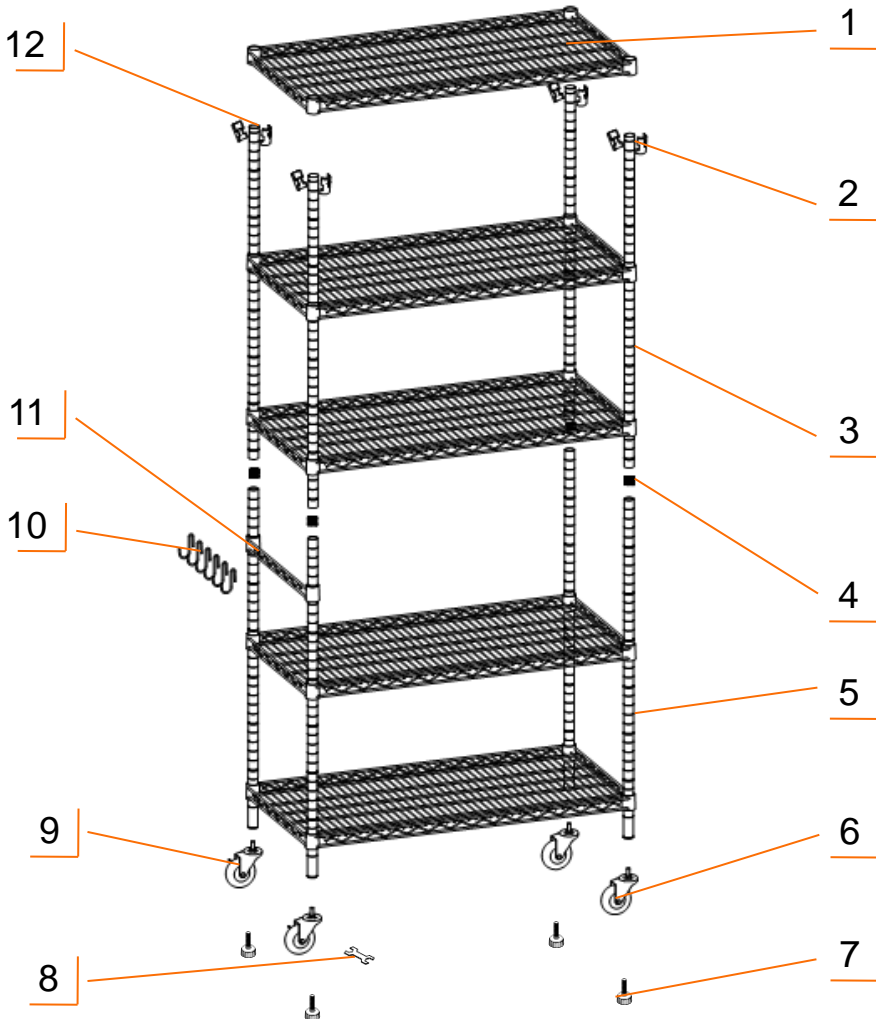



---

## WARNINGS

1. **Read and understand all instructions.** Failure to follow all instructions may result in injury and/or damage.
2. **Use the provided caster wrench to tighten casters completely.** Failure to do as instructed could result in the caster stem breaking thereby causing the shelving rack to collapse.
3. **The warnings, cautions, and instructions discussed in this manual cannot cover all possible conditions or situations that may occur.** The user must always be aware of their environment and ensure that they use the product in a safe and responsible manner.
4. **Do NOT modify the product in any way.** Unauthorized modification may impair the function and/or safety of the product, and may affect the life of the product. Any modifications will void product warranty.
5. **Check for damaged parts.** Before using this product, carefully check that all parts are in good condition, and that the product will operate properly and perform its intended function. Check for damaged parts and any other conditions that may affect the operation of this product. Replace damaged or worn parts, and never use this product with a damaged part.
6. **Do NOT overload the product.**

Weight capacity per Shelf on Feet Levelers	<b>800 lb (evenly distributed)</b>
Weight capacity per Shelf on Casters	<b>160 lb (evenly distributed)</b>
Total weight capacity of Shelving Rack (evenly distributed)	<b>800 lb (on Casters) 4000 lb (on Feet Levelers)</b>

7. **Do NOT roll the product on an uneven surface.** Only move the product on a smooth surface. Rolling over rough or uneven surface may cause casters to break or items on the product to fall, resulting in injury and / or damage.
8. **Do NOT allow children to climb or play around the product.** Tipping may occur causing injury.
9. **Load the product evenly and place the heaviest items on the lower shelves.**

---

## CARE AND MAINTENANCE

- Avoid harsh, abrasive cleaners, and other corrosive chemicals.
- This item is not recommended for outdoor use.

# PRODUCT REGISTRATION

Thank you for purchasing a TRINITY 5-Tier NSF Wire Shelving Rack w/Wheels. In order to register your product and receive streamlined customer service, please fill out the following Product Registration Form and (1) fax the form to 310.347.4134 (2) complete the Product Registration Form online at [www.trinityii.com](http://www.trinityii.com) or (3) scan and email the form to [customerservice@trinityii.com](mailto:customerservice@trinityii.com). Include a copy of your original receipt with your submission.

First Name: \_\_\_\_\_ Last Name: \_\_\_\_\_

Address: \_\_\_\_\_

City: \_\_\_\_\_ State: \_\_\_\_\_ Zip Code: \_\_\_\_\_

Email Address: \_\_\_\_\_ Phone: \_\_\_\_\_

Product Model #: \_\_\_\_\_ Purchase Date: \_\_\_\_ / \_\_\_\_ / \_\_\_\_

Location of Purchase: \_\_\_\_\_

Please rate the importance of each feature (1=least important; 10=most important)

Quality \_\_\_\_ Price \_\_\_\_ Size/Capacity \_\_\_\_ Appearance \_\_\_\_ Other \_\_\_\_

How did you hear about our product?

- Magazine Ad     Catalog     Salesperson     Word of Mouth  
 Internet     Store Display     Other

Marital Status:                       Single                                       Married

Household Income:                 Below \$50,000     \$50,000-\$150,000     \$150,000+

Education:                             High School     College     Graduate School

Primary Residence:                 Own                                       Rent

Comments/Suggestions:



---

# 1 YEAR LIMITED WARRANTY

## TRINITY 5-Tier NSF Wire Shelving Rack w/Wheels Model # TBFZ-0906 / TFBPBK-0906

Trinity International Industries (“Trinity”) warrants to the original consumer purchaser (“Purchaser”) of the TRINITY 5-Tier NSF Wire Shelving Rack w/Wheels (“Product”) that each Product shall be free from defects in workmanship and materials for a period of 1 year from the date of original purchase. Trinity’s obligation under this warranty shall be limited to repair or replacement of, or adequate compensation for the Product which shall not be greater than the amount of the purchase price of the Product, at the option of Trinity, during the warranty period. All replaced parts and Products become the property of Trinity and must be returned to Trinity.

This warranty excludes normal wear and tear of the Product and its parts or components, and damage arising from any of the following: negligent use or misuse of the Product, use contrary to this User’s Manual, or alteration by any one other than Trinity. The warranty period of 1 year shall not be extended or renewed by the repair or replacement of, or compensation for, the Product. Any warranty implied by applicable law is limited in duration to one year from the date of purchase and is subject to the same conditions and limitations as is provided for our express warranty.

Except as set forth herein, and to the extent of applicable there are no warranties on this Product either express or implied, and Trinity disclaims all warranties including, but not limited to, any implied warranties of merchantability, infringement or fitness for a particular purpose. No warranty or guarantee given by any person, firm, or corporation with respect to this product shall be binding on Trinity.

If your Product is defective or otherwise requires service or parts, please call TRINITY Customer Service toll-free at (800) 985-5506, between 5:00 a.m. and 5:00 p.m., PST. Please tell us which model you purchased, the date of the purchase, and the problem with your Product. A copy of your original purchase receipt must accompany your service request.

### LIMITATION OF REMEDIES AND LIABILITY

Trinity (and its employees, officers, members, managers, affiliates and assigns) shall not be liable for any incidental, consequential, special, indirect, remote, special or punitive damages for breach of any warranty, express or implied, including, but not limited to, lost profits, lost savings, loss of anticipated benefits and attorneys’ fees, which arise out of the purchase, use or inability to use the Product, whether arising out of contract, negligence, strict tort, product liability, or any other legal theory on which a claim is based. As noted above, to the extent damages are allowed by our express warranty or by applicable law, those damages may not exceed the purchase price paid for the Product. Without limiting the foregoing Purchaser assumes all risk and liability for loss, damage or injury to Purchaser and Purchaser’s property and to others and their property arising out of the use, misuse, or inability to use this Product. This limited warranty shall not extend to anyone other than the original purchaser of this product, is nontransferable and states your exclusive remedy.

Some states do not allow the exclusion or limitation of incidental, consequential, special, or punitive damages, so the above limitation or exclusion may not apply to you. The above warranty gives you specific legal rights, and you may have other rights which vary from state to state.

---

## CONTACT US

**QUESTIONS? NEED PARTS?  
WE ARE HERE TO HELP!**

**Please feel free to contact us. There are no questions too small, or any problems too big. We're committed to providing our customers with the highest level of service.**

### **TRINITY Customer Service**

**TEL: 800.985.5506**

**FAX: 310.347.4134**

**EMAIL: [customerservice@trinityii.com](mailto:customerservice@trinityii.com)**

**Monday through Friday  
5:00 AM – 5:00 PM (PST)**

**[www.trinityii.com](http://www.trinityii.com)**