

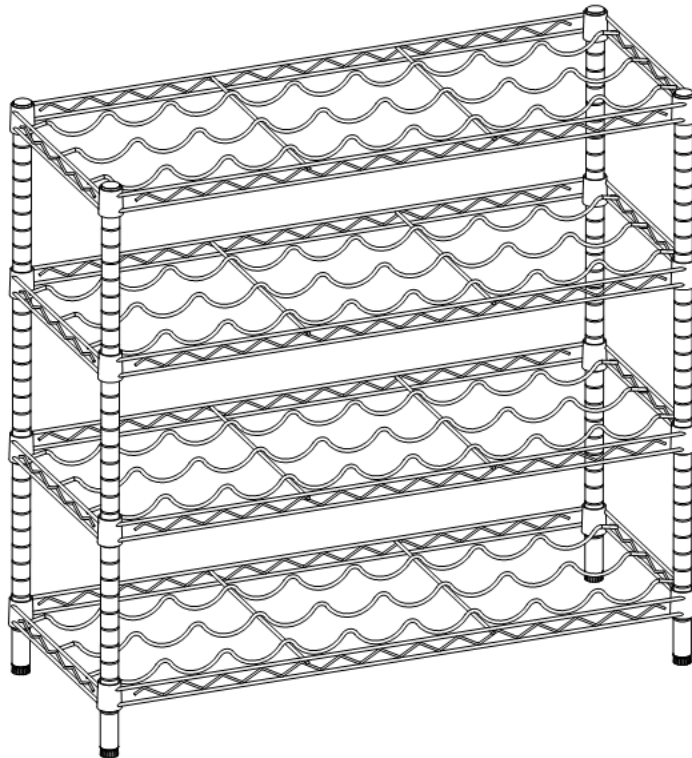

OWNER'S MANUAL



TRINITY ECOSTORAGE™ 4-TIER NSF WINE RACK

Model # TBFZ-0908



Important / Important / Importante

FOR QUICK & EASY 3D ASSEMBLY INSTRUCTIONS

POUR DES DIRECTIVES D'ASSEMBLAGE 3D RAPIDES ET FACILES

PARA INSTRUCCIONES DE ENSAMBLAJE RÁPIDAS Y SENCILLAS EN 3D

BILT.[®]

Intelligent Instructions
Directives intelligentes
Instrucciones Inteligentes



DOWNLOAD THE FREE APP | TÉLÉCHARGER L'APPLICATION GRATUITE | DESCARGUE LA APLICACIÓN GRATUITA

PARTS LIST

Your TRINITY EcoStorage™ 4-Tier Wine Rack should include the following parts. Please inspect box contents to ensure you have received all components.

If you are missing any parts, need assistance with assembly or have questions, please contact TRINITY Customer Service: 800.985.5506 or customerservice@trinityii.com. Parts can also be requested online via “Contact Us” section at www.trinityii.com.

You will NOT need additional tools for assembly.

A

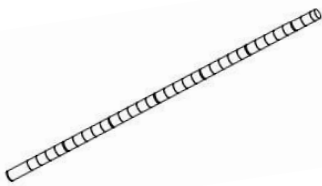

POLE (4)

End Cap (4), Threaded Insert (4) and Feet Leveler (4) pre-installed

B

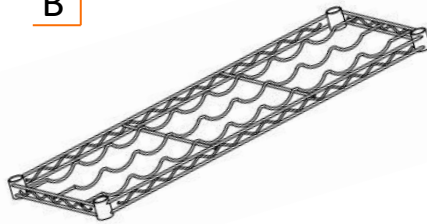

SHELF (4)

C



SLIP SLEEVE (32) + (2) extra

D



POLE CONNECTOR (4)

Only use when connecting another unit to make 8-Tier Wine Rack



Note: The black circular plastic spacers in between Shelves are used only for packaging purposes. They are NOT needed. Please discard.

ASSEMBLY INSTRUCTIONS

STEP 1

Note that each POLE (A) has slight horizontal line indentations at 1" intervals. Each SLIP SLEEVE (C) has raised horizontal lines inside designed to lock them in place on POLE (A).

On POLE (A), place one pair of SLIP SLEEVES (C) at desired height **no higher than 3rd** indentation from bottom. Please make sure arrow faces up and word "TOP" is right side up.

Slide pair of SLIP SLEEVES (C) until you hear a click to confirm the pair is locked onto POLE (A). Do this for each POLE (A) and make sure height is identical for each POLE (A). Do NOT place more than one pair on each pole at a time.

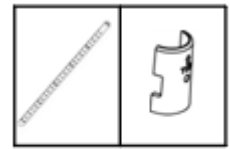

A (4) C (8)

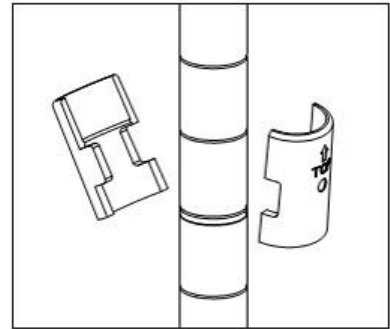

Note: There will be a very small gap in-between two locked SLIP SLEEVES (C)—this is normal.

STEP 2

Place SHELF (B) on its side and slide each POLE (A) through each corner cylinder on the SHELF (B). Make sure SHELF (B) corner cylinders are positioned over SLIP SLEEVES (C).

Stand the unit upright.

Note:

- Level side of SHELF (B) is TOP side (TRINITY logo on corner cylinders should be right-side up.)
- Use a rubber mallet, if needed, to secure SHELF (B).



B (1)

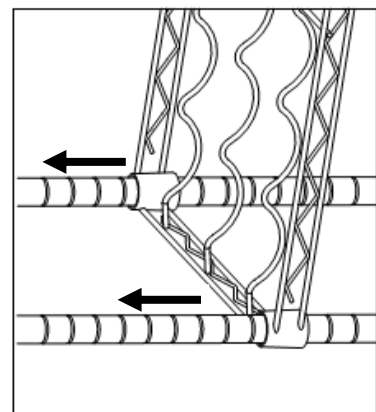

ASSEMBLY INSTRUCTIONS

STEP 3

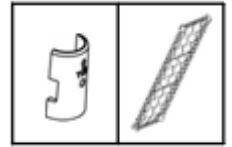

C (24)

B (3)

On POLE (A), place 1 pair of SLIP SLEEVES (C) at the desired distance between SHELVES (B). Please make sure the arrow faces up and that the word "TOP" is right side up. Do this for each POLE (A), and make sure height is identical for each POLE (A).

Lower SHELF (B) over each POLE (A) so corner cylinders of SHELF (B) are positioned over SLIP SLEEVES (C).

Repeat Step 3 to install other SHELVES (B) as desired.

Note: Use a rubber mallet, if needed, to secure SHELF (B).

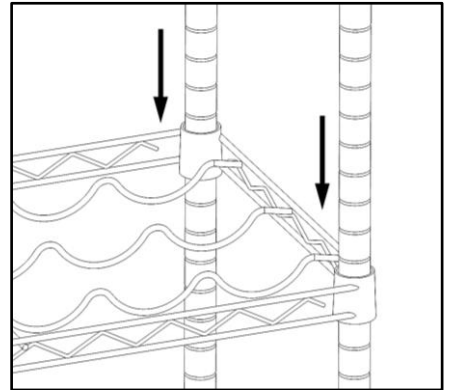

STEP 4

Feet Levelers are already screwed into POLES (A), and you can adjust as needed to ensure Shelving Rack is level.

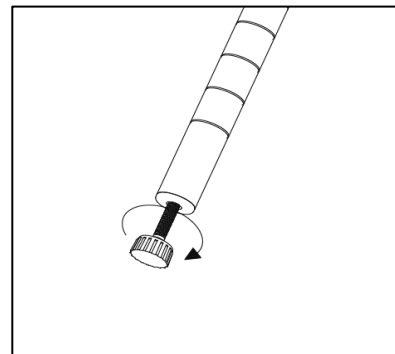

ASSEMBLY INSTRUCTIONS

STEP 5

Purchase another TRINITY 4-TIER WINE RACK.
Fully assemble one unit first. Remove black
END CAPS from all poles.

Screw POLE CONNECTORS (D) to second unit's
loose POLES where END CAPS have been taken
off.

Screw POLES (A) with POLE CONNECTORS (D) to
top of POLES (A) of assembled unit.

Install remaining SHELVES (B) as desired.

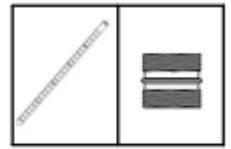

A (4)

D (4)

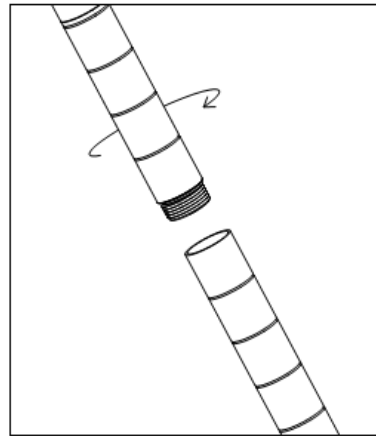

SERVICE PARTS LIST – TBFZ-0908 Chrome

TRINITY Customer Service provides the following replacement parts:

| | Part Number | Description | Part Number | Description | |
|----|--------------------|--------------------|--------------------|--------------------|----------------|
| 1) | ZSV-03-009-3614 | Shelf | 4) | XBK-98-003-2538 | Feet Leveler |
| 2) | XBK-01-011-2543 | Slip Sleeve | 5) | XBK-23-004-2517 | End Cap |
| 3) | ZSV-04-008-3400 | Pole | 6) | ZSV-01-013-2523 | Pole Connector |

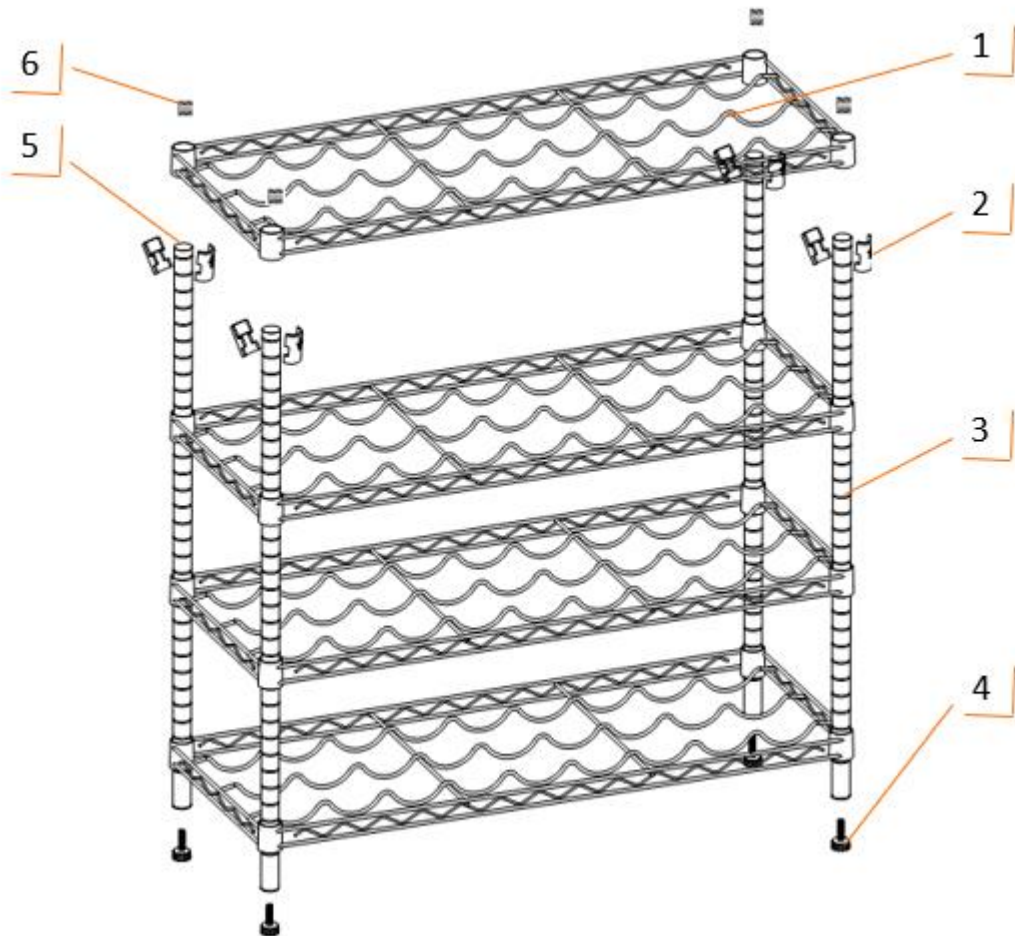

WARNINGS

1. **Read and understand all instructions.** Failure to follow all instructions may result in injury and/or damage.
2. **The warnings, cautions, and instructions discussed in this manual cannot cover all possible conditions or situations that may occur.** The user must always be aware of their environment and ensure that they use the product in a safe and responsible manner.
3. **Do NOT modify the product in any way.** Unauthorized modification may impair the function and/or safety of the product, and may affect the life of the product. Any modifications will void product warranty.
4. **Check for damaged parts.** Before using this product, carefully check that all parts are in good condition, and that the product will operate properly and perform its intended function. Check for damaged parts and any other conditions that may affect the operation of this product. Replace damaged or worn parts, and never use this product with a damaged part.
5. **Do NOT overload the product.**

| | |
|------------------------------------|---|
| Weight capacity per Shelf | Up to (9) 750 mL wine bottles OR 150 lb (evenly distributed) |
| Total weight capacity of Wine Rack | 600 lb (evenly distributed) |

CARE AND MAINTENANCE

- Avoid harsh, abrasive cleaners, and other corrosive chemicals.
- This product is for in door use only.



PRODUCT REGISTRATION

Thank you for purchasing a TRINITY EcoStorage™ 4-Tier NSF Wine Rack. In order to register your product and receive streamlined customer service, please fill out the following Product Registration Form and (1) fax the form to 310.347.4134 (2) complete the Product Registration Form online at www.trinityii.com or (3) scan and email the form to customerservice@trinityii.com. Include a copy of your original receipt with your submission.

First Name: _____ Last Name: _____

Address: _____

City: _____ State: _____ Zip Code: _____

Email Address: _____ Phone: _____

Product Model #: _____ TBFZ-0908 _____ Purchase Date: ____ / ____ / ____

Location of Purchase: _____

Please rate the importance of each feature (1=least important; 10=most important)

Quality ____ Price ____ Size/Capacity ____ Appearance ____ Other ____

How did you hear about our product?

- Magazine Ad Catalog Salesperson Word of Mouth
 Internet Store Display Other

- Marital Status: Single Married
Household Income: Below \$50,000 \$50,000-\$150,000 \$150,000+
Education: High School College Graduate School
Primary Residence: Own Rent

Comments/Suggestions:





1 YEAR LIMITED WARRANTY

TRINITY EcoStorage™ 4-Tier NSF Wine Rack Model # TBFZ-0908

Trinity International Industries (“Trinity”) warrants to the original consumer purchaser (“Purchaser”) of the EcoStorage™ 4-Tier NSF Wine Rack (“Product”) that each Product shall be free from defects in workmanship and materials for a period of 1 year from the date of original purchase. Trinity’s obligation under this warranty shall be limited to repair or replacement of, or adequate compensation for the Product which shall not be greater than the amount of the purchase price of the Product, at the option of Trinity, during the warranty period. All replaced parts and Products become the property of Trinity and must be returned to Trinity.

This warranty excludes normal wear and tear of the Product and its parts or components, and damage arising from any of the following: negligent use or misuse of the Product, use contrary to this User’s Manual, or alteration by any one other than Trinity. The warranty period of 1 year shall not be extended or renewed by the repair or replacement of, or compensation for, the Product. Any warranty implied by applicable law is limited in duration to one year from the date of purchase and is subject to the same conditions and limitations as is provided for our express warranty.

Except as set forth herein, and to the extent of applicable there are no warranties on this Product either express or implied, and Trinity disclaims all warranties including, but not limited to, any implied warranties of merchantability, infringement or fitness for a particular purpose. No warranty or guarantee given by any person, firm, or corporation with respect to this product shall be binding on Trinity.

If your Product is defective or otherwise requires service or parts, please call TRINITY Customer Service toll-free at (800) 985-5506, between 5:00 a.m. and 5:00 p.m., PST. Please tell us which model you purchased, the date of the purchase, and the problem with your Product. A copy of your original purchase receipt must accompany your service request.

LIMITATION OF REMEDIES AND LIABILITY

Trinity (and its employees, officers, members, managers, affiliates and assigns) shall not be liable for any incidental, consequential, special, indirect, remote, special or punitive damages for breach of any warranty, express or implied, including, but not limited to, lost profits, lost savings, loss of anticipated benefits and attorneys’ fees, which arise out of the purchase, use or inability to use the Product, whether arising out of contract, negligence, strict tort, product liability, or any other legal theory on which a claim is based. As noted above, to the extent damages are allowed by our express warranty or by applicable law, those damages may not exceed the purchase price paid for the Product. Without limiting the foregoing Purchaser assumes all risk and liability for loss, damage or injury to Purchaser and Purchaser’s property and to others and their property arising out of the use, misuse, or inability to use this Product. This limited warranty shall not extend to anyone other than the original purchaser of this product, is nontransferable and states your exclusive remedy.

Some states do not allow the exclusion or limitation of incidental, consequential, special, or punitive damages, so the above limitation or exclusion may not apply to you. The above warranty gives you specific legal rights, and you may have other rights which vary from state to state.

CONTACT US

**QUESTIONS? NEED PARTS?
WE ARE HERE TO HELP!**

Please feel free to contact us. There are no questions too small, or any problems too big. We're committed to providing our customers with the highest level of service.

TRINITY Customer Service

TEL: 800.985.5506

FAX: 310.347.4134

EMAIL: customerservice@trinityii.com

**Monday through Friday
5:00 AM – 5:00 PM (PST)**

www.trinityii.com