

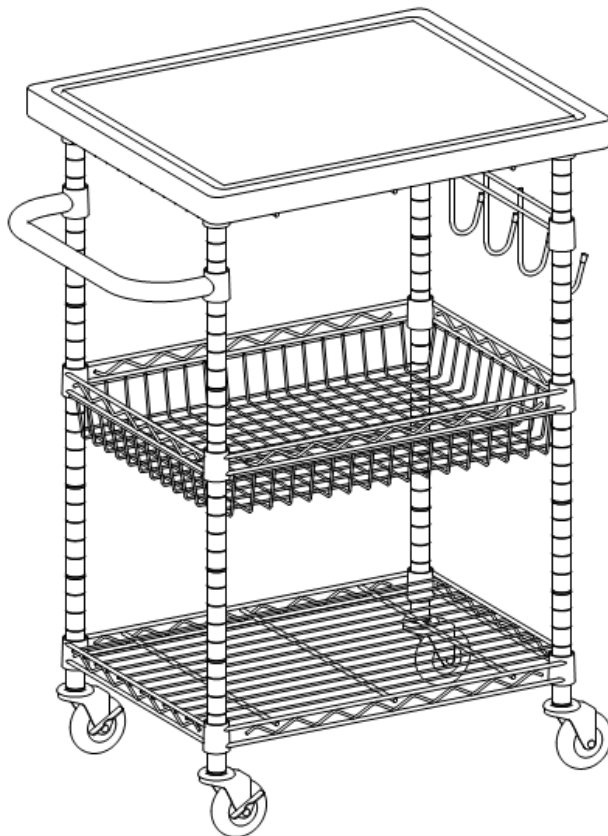

## OWNER'S MANUAL



### TRINITY ECOSTORAGE® BAMBOO TOP KITCHEN CART

Model # TBFZ-1401



Important / Important / Importante

FOR QUICK & EASY 3D ASSEMBLY INSTRUCTIONS

POUR DES DIRECTIVES D'ASSEMBLAGE 3D RAPIDES ET FACILES

PARA INSTRUCCIONES DE ENSAMBLAJE RÁPIDAS Y SENCILLAS EN 3D

# BILT.®

Intelligent Instructions  
Directives intelligentes  
Instrucciones Inteligentes



DOWNLOAD THE FREE APP | TÉLÉCHARGER L'APPLICATION GRATUITE | DESCARGUE LA APLICACIÓN GRATUITA

# PARTS LIST

Your TRINITY EcoStorage® Bamboo Top Kitchen Cart should include the following parts. Please inspect box contents to ensure you have received all components.

If you are missing any parts, need assistance with assembly or have questions, please contact TRINITY Customer Service: 800.985.5506 or [customerservice@trinityii.com](mailto:customerservice@trinityii.com). Parts can also be requested online via "Contact Us" section at [www.trinityii.com](http://www.trinityii.com).

You will NOT need additional tools for assembly.

**A**

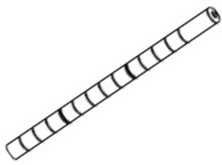

**BOTTOM POLE (4)**  
Threaded Insert (4)  
pre-installed

**B**

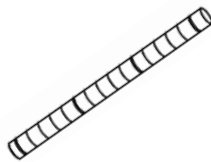

**TOP POLE (4)**  
End Cap (4) and  
Pole Connector (4)  
pre-installed

**C**



**BASKET (1)**

**D**

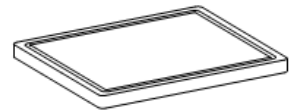

**BAMBOO  
CUTTING BOARD (1)**

**E**



**SHELF – LIP DOWN (1)**

**F**

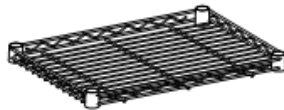

**SHELF – LIP UP (1)**

**G**

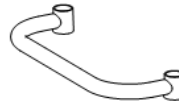

**CART HANDLE (1)**

**H**

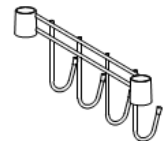

**SIDEBAR  
w/4 HOOKS (1)**

**I**



**SLIP SLEEVE  
(32) + (2) extra**

**J**



**LOCKING  
CASTER (2)**

**K**



**NON-LOCKING  
CASTER (2)**

**L**



**WRENCH (1)**



*Note: The black circular plastic spacers in between Shelves are used only for packaging purposes. They are NOT needed. Please discard.*

# ASSEMBLY INSTRUCTIONS

## STEP 1

Screw each CASTER (J & K) into bottom of each BOTTOM POLE (A). Turn clockwise to screw in place. Make sure LOCKING CASTERS are on the same side.

**Use provided caster wrench to tighten completely. Failure to do as instructed could result in caster stem breaking.**

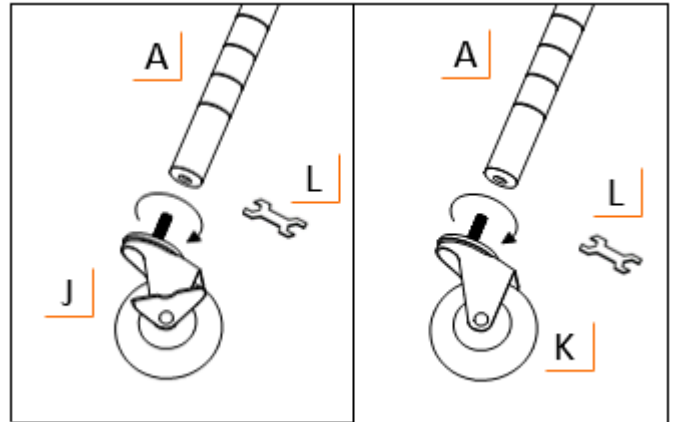
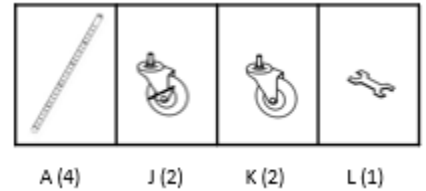

## STEP 2

Note that POLES (A+B) has slight horizontal line indentations at 1" intervals. Each SLIP SLEEVE (I) has raised horizontal lines inside designed to lock them in place on POLES (A+B).

On BOTTOM POLE (A), place 1 pair of SLIP SLEEVES (I) at desired height **no higher than 3<sup>rd</sup>** indentation from the bottom. Please make sure arrow faces up and word "TOP" is right-side up. Do this for each BOTTOM POLE (A) and make sure slip sleeve heights are identical for all BOTTOM POLES (A).

Slide pair of SLIP SLEEVES (I) until you hear a click to confirm the pair is locked onto BOTTOM POLE (A). Do NOT place more than one pair on each BOTTOM POLE (A) at a time. Do this for each BOTTOM POLE (A) and make sure height is identical for each BOTTOM POLE (A).

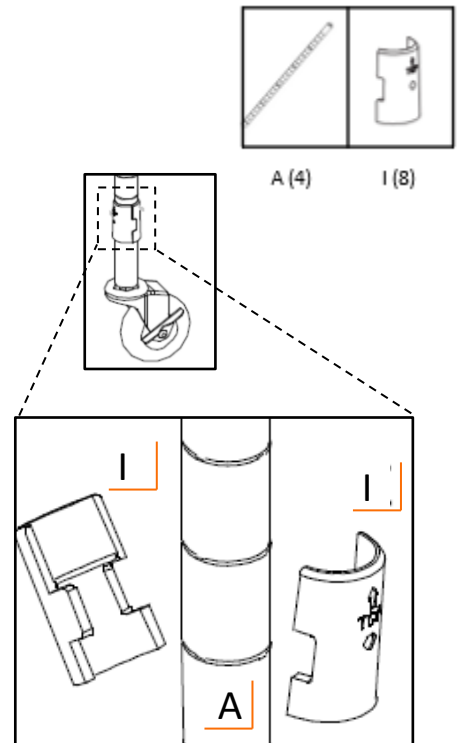

*Note: There will be a very small gap in-between two locked SLIP SLEEVES (I)—this is normal.*

# ASSEMBLY INSTRUCTIONS

## STEP 3



E (1)

Place SHELF – LIP DOWN (E) on its side and slide each BOTTOM POLE (A) through each corner cylinder on SHELF – LIP DOWN (E). Make sure SHELF – LIP DOWN (E) corner cylinders are positioned over SLIP SLEEVES (I).

Stand the unit upright.

*Note:*

- Level side of SHELF – LIP DOWN (E) is TOP side (TRINITY logo on corner cylinders should be right-side up.)
- Use a rubber mallet, if needed, to secure SHELF – LIP DOWN (E).
- For convenience, place BOTTOM POLES (A) with Locking Casters on the same side of shelf.

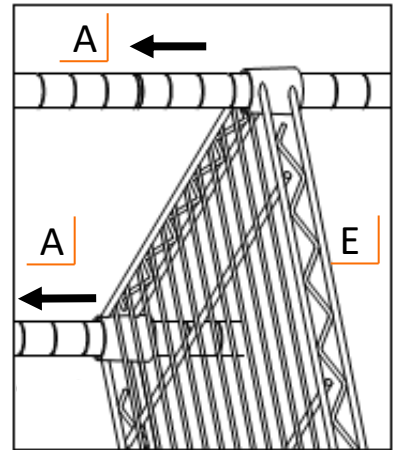

## STEP 4



B (4)

Screw TOP POLES (B) into BOTTOM POLES (A). Pole Connectors are pre-installed in bottom of TOP POLES (B).

*Note: The top of each TOP POLE (B) is indicated by a BLACK END CAP.*

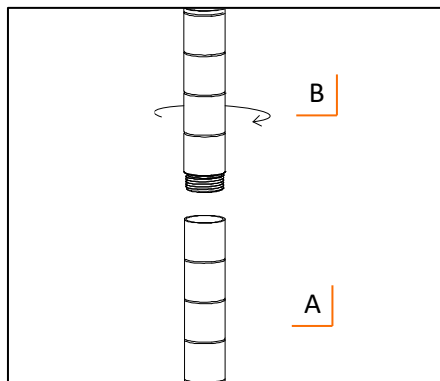

# ASSEMBLY INSTRUCTIONS

## STEP 5

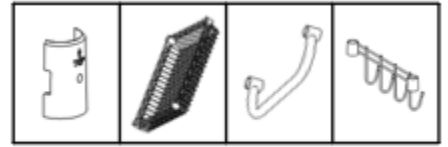

I (16)

C (1)

G (1)

H (1)

Repeat Step 2 & 3 to assemble BASKET (C), CART HANDLE (G), and SIDEBAR w/4 HOOKS (H)

Only install ONE item at a time. Make sure to put SLIP SLEEVES (I) at desired heights for each item.

*Note:*

- Use a rubber mallet, if needed, to secure BASKET(C), CART HANDLE (G), and SIDEBAR w/4 HOOKS (H).

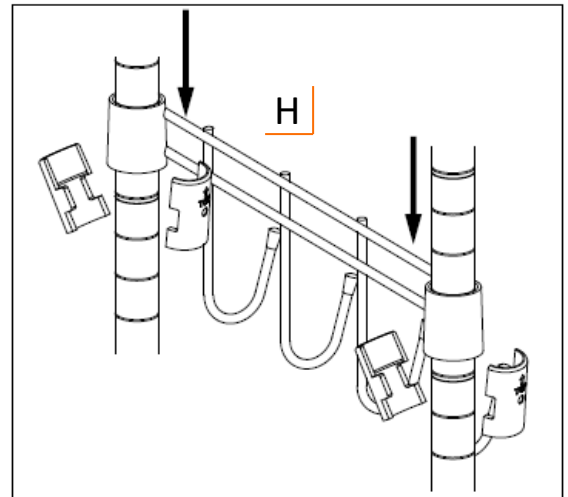
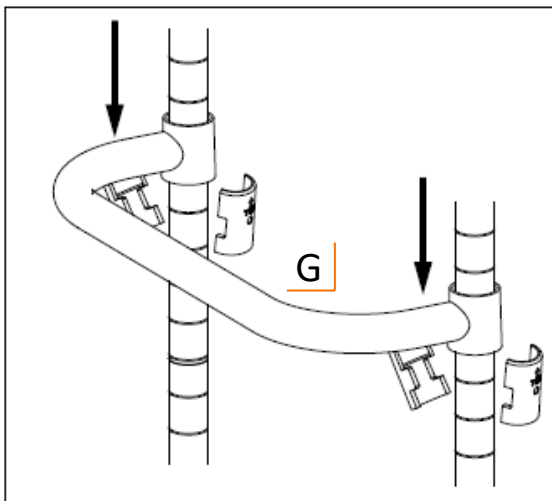
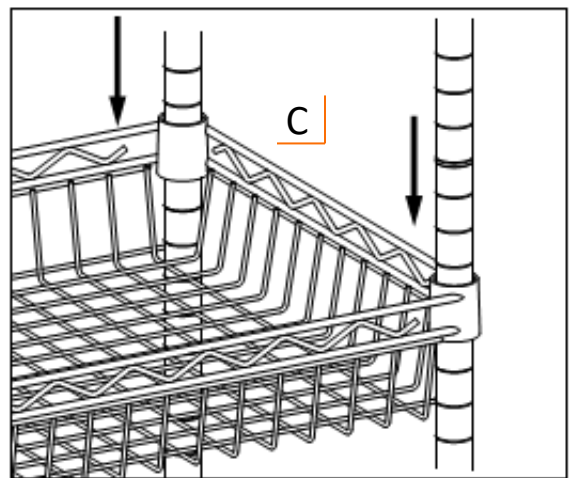
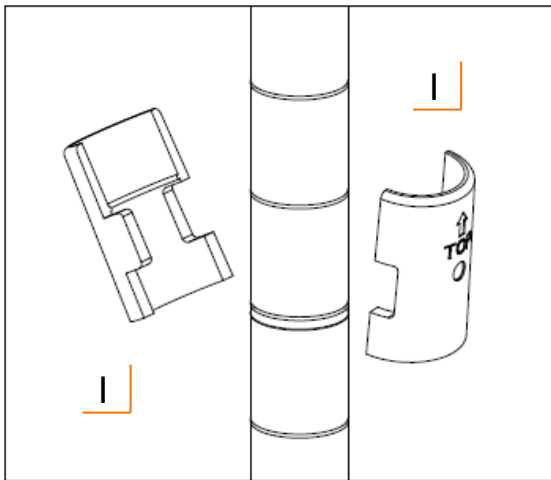

# ASSEMBLY INSTRUCTIONS

## STEP 6

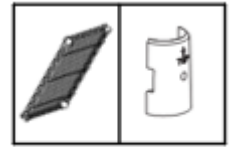

F (1)

I (8)

Place SLIP SLEEVES (I) at highest position on TOP POLES (B). Slide SHELF – LIP UP (F) onto SLIP SLEEVES (I).

*Note:*

- Use a rubber mallet, if needed, to secure SHELF – LIP UP (F).

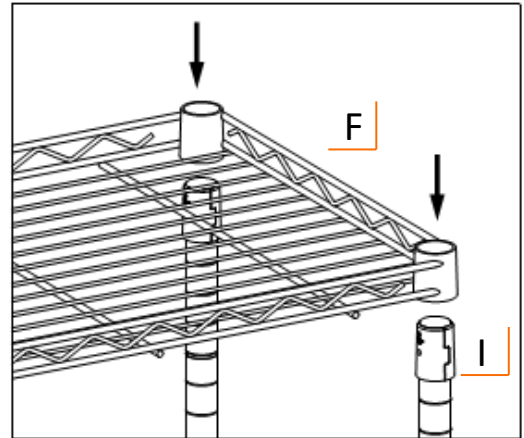

## STEP 7



D (1)

Place BAMBOO CUTTING BOARD (D) on top of SHELF – LIP UP (F). The grooves on the bottom of BAMBOO CUTTING BOARD (D) will fit exactly on SHELF – LIP UP (F).

*Note:*

- Remove BAMBOO CUTTING BOARD (D) to clean thoroughly.
- Using food safe oil regularly will prevent your BAMBOO CUTTING BOARD (D) from becoming dry and brittle.

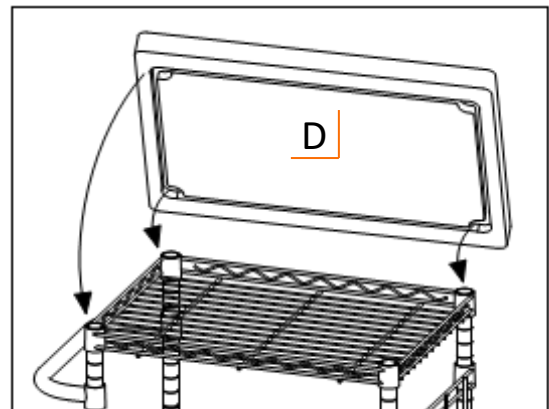

# SERVICE PARTS LIST – TBFZ-1401 Chrome Color

TRINITY Customer Service provides the following replacement parts:

Part Number	Description	Part Number	Description
1) ONA-20-001-2420	Bamboo Board	8) XXX-97-002-0001	Wrench
2) ZSV-03-008-2216	Shelf (lip up)	9) ZSV-99-008-3010	Locking Caster
3) XBK-01-012-2543	Slip Sleeve	10) ZSV-04-031-1525	Bottom Pole
4) ZSV-02-007-0001	Sidebar w/ 4 Hooks	11) ZSV-01-030-2523	Pole Connector
5) ZSV-21-005-2216	Basket	12) ZSV-04-029-1675	Top Pole
6) ZSV-03-007-2216	Shelf (lip down)	13) ZSV-05-006-1600	Cart Handle
7) ZSV-99-007-3010	Non-locking Caster	14) XBK-23-004-2517	End Cap

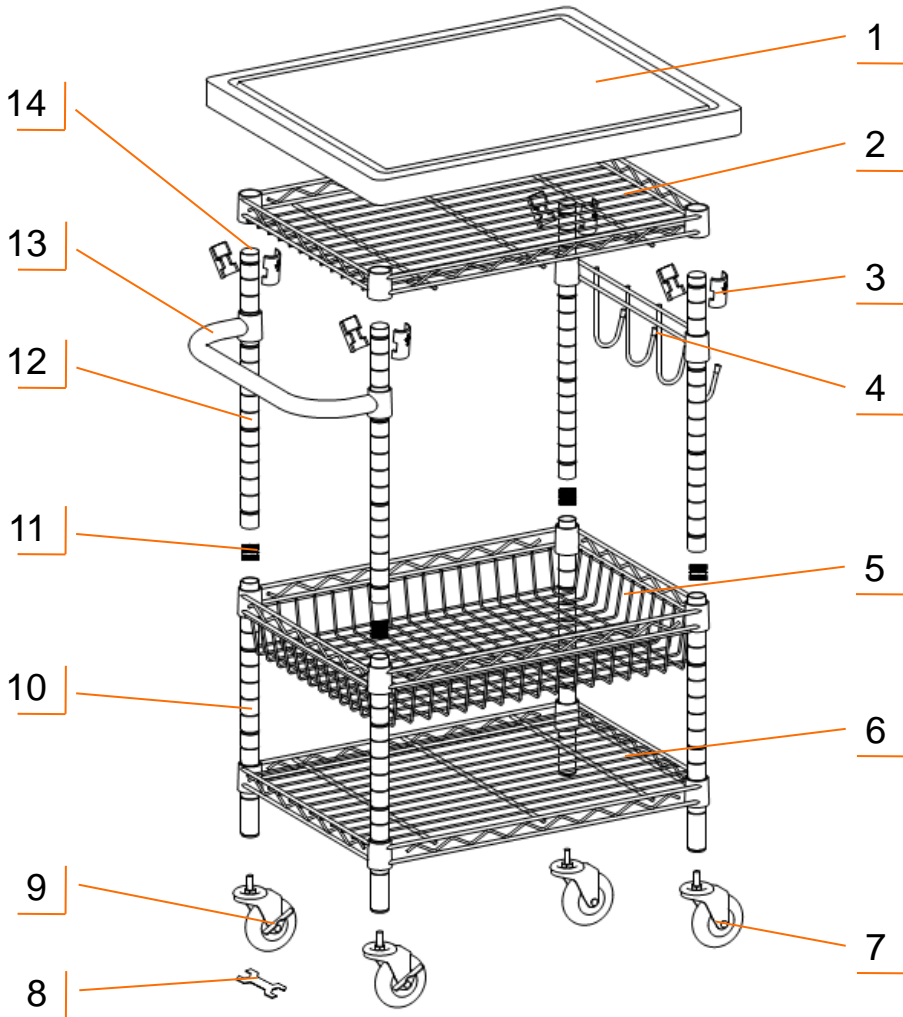

## WARNINGS

- 1. Read and understand all instructions.** Failure to follow all instructions may result in injury and/or damage.
- 2. Use the provided caster wrench to tighten casters completely.** Failure to do as instructed could result in the caster stem breaking thereby causing the product to collapse.
- 3. The warnings, cautions, and instructions discussed in this manual cannot cover all possible conditions or situations that may occur.** The user must always be aware of the environment and ensure to use the product in a safe and responsible manner.
- 4. Do NOT modify the product in any way.** Unauthorized modification may impair the function and/or safety of the product, and may affect the life of the product. Any modifications will void product warranty.
- 5. Check for damaged parts.** Before using this product, carefully check that all parts are in good condition, and that the product will operate properly and perform its intended function. Check for damaged parts and any other conditions that may affect the operation of this product. Replace damaged or worn parts, and never use this product with a damaged part.
- 6. Do NOT overload the product.**

Weight capacity per Shelf (evenly distributed)	<b>200 lb</b>
Weight capacity per Basket (evenly distributed)	<b>65 lb</b>
Total weight capacity of Cart (evenly distributed)	<b>500 lb</b>

- 7. Do NOT allow children to climb or play around the product.** Tipping may occur causing injury.
- 8. Do NOT stand or lean on the product or use any part of this product as a step ladder.** Tipping may occur causing injury.
- 9. Do NOT roll the product on an uneven surface.** Only move the product on a smooth surface. Rolling over rough or uneven surfaces may cause casters to break or items on the product to fall, resulting in injury and / or damage. Wood and laminate flooring can be scratched or dented. Ensure your flooring can bear the weight of loaded product before rolling loaded product across your flooring.
- 10. Make sure that the wheels are LOCKED when using the bamboo board as a cutting or work surface.**
- 11. Do NOT leave knives or sharp objects on the bamboo top unattended.**



---

## CARE AND MAINTENANCE

- Avoid harsh, abrasive cleaners, and other corrosive chemicals.
- Bamboo board should be hand washed only and periodically treated with food safe oil.
- The product is designed for indoor use.



# PRODUCT REGISTRATION

Thank you for purchasing a TRINITY EcoStorage® Bamboo Top Kitchen Cart. In order to register your product and receive streamlined customer service, please fill out the following Product Registration Form and (1) fax the form to 310.347.4134 (2) complete the Product Registration Form online at [www.trinityii.com](http://www.trinityii.com) or (3) scan and email the form to [customerservice@trinityii.com](mailto:customerservice@trinityii.com). Include a copy of your original receipt with your submission.

First Name: \_\_\_\_\_ Last Name: \_\_\_\_\_

Address: \_\_\_\_\_

City: \_\_\_\_\_ State: \_\_\_\_\_ Zip Code: \_\_\_\_\_

Email Address: \_\_\_\_\_ Phone: \_\_\_\_\_

Product Model #: TBFZ-1401 Purchase Date: \_\_\_\_ / \_\_\_\_ / \_\_\_\_

Location of Purchase: \_\_\_\_\_

Please rate the importance of each feature (1=least important; 10=most important)

Quality \_\_\_\_ Price \_\_\_\_ Size/Capacity \_\_\_\_ Appearance \_\_\_\_ Other \_\_\_\_

How did you hear about our product?

- Magazine Ad     Catalog     Salesperson     Word of Mouth  
 Internet     Store Display     Other

Marital Status:                       Single                       Married

Household Income:                 Below \$50,000     \$50,000-\$150,000     \$150,000+

Education:                           High School             College             Graduate School

Primary Residence:                 Own                       Rent

Comments/Suggestions:



---

# 1 YEAR LIMITED WARRANTY

## TRINITY EcoStorage® Bamboo Top Kitchen Cart Model # TBFZ-1401

Trinity International Industries (“Trinity”) warrants to the original consumer purchaser (“Purchaser”) of the TRINITY EcoStorage® Bamboo Top Kitchen Cart (“Product”) that each Product shall be free from defects in workmanship and materials for a period of 1 year from the date of original purchase. Trinity’s obligation under this warranty shall be limited to repair or replacement of, or adequate compensation for the Product which shall not be greater than the amount of the purchase price of the Product, at the option of Trinity, during the warranty period. All replaced parts and Products become the property of Trinity and must be returned to Trinity.

This warranty excludes normal wear and tear of the Product and its parts or components, and damage arising from any of the following: negligent use or misuse of the Product, use contrary to this User’s Manual, or alteration by any one other than Trinity. The warranty period of 1 year shall not be extended or renewed by the repair or replacement of, or compensation for, the Product. Any warranty implied by applicable law is limited in duration to one year from the date of purchase and is subject to the same conditions and limitations as is provided for our express warranty.

Except as set forth herein, and to the extent of applicable there are no warranties on this Product either express or implied, and Trinity disclaims all warranties including, but not limited to, any implied warranties of merchantability, infringement or fitness for a particular purpose. No warranty or guarantee given by any person, firm, or corporation with respect to this product shall be binding on Trinity.

If your Product is defective or otherwise requires service or parts, please call TRINITY Customer Service toll-free at (800) 985-5506, between 5:00 a.m. and 5:00 p.m., PST. Please tell us which model you purchased, the date of the purchase, and the problem with your Product. A copy of your original purchase receipt must accompany your service request.

### LIMITATION OF REMEDIES AND LIABILITY

Trinity (and its employees, officers, members, managers, affiliates and assigns) shall not be liable for any incidental, consequential, special, indirect, remote, special or punitive damages for breach of any warranty, express or implied, including, but not limited to, lost profits, lost savings, loss of anticipated benefits and attorneys’ fees, which arise out of the purchase, use or inability to use the Product, whether arising out of contract, negligence, strict tort, product liability, or any other legal theory on which a claim is based. As noted above, to the extent damages are allowed by our express warranty or by applicable law, those damages may not exceed the purchase price paid for the Product. Without limiting the foregoing Purchaser assumes all risk and liability for loss, damage or injury to Purchaser and Purchaser’s property and to others and their property arising out of the use, misuse, or inability to use this Product. This limited warranty shall not extend to anyone other than the original purchaser of this product, is nontransferable and states your exclusive remedy.

Some states do not allow the exclusion or limitation of incidental, consequential, special, or punitive damages, so the above limitation or exclusion may not apply to you. The above warranty gives you specific legal rights, and you may have other rights which vary from state to state.

---

## CONTACT US

**QUESTIONS? NEED PARTS?  
WE ARE HERE TO HELP!**

**Please feel free to contact us. There are no questions too small, or any problems too big. We're committed to providing our customers with the highest level of service.**

### **TRINITY Customer Service**

**TEL: 800.985.5506**

**FAX: 310.347.4134**

**EMAIL: [customerservice@trinityii.com](mailto:customerservice@trinityii.com)**

**Monday through Friday  
5:00 AM – 5:00 PM (PST)**

**[www.trinityii.com](http://www.trinityii.com)**