

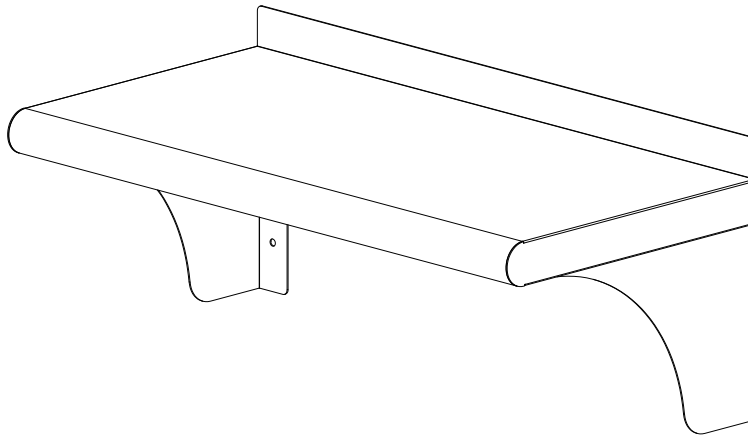

OWNER'S MANUAL



TRINITY EcoStorage® 24" Stainless Steel Wall Shelf Model# THA-3328 / THA-33282 (2-pack)

Important / Important / Importante

FOR 3D ASSEMBLY INSTRUCTIONS
POUR DES DIRECTIVES D'ASSEMBLAGE 3D
PARA INSTRUCCIONES DE ENSAMBLAJE EN 3D



BILT.[®]

Intelligent Instructions
Directives intelligentes
Instrucciones Inteligentes



PARTS LIST

Your TRINITY EcoStorage® 24" Stainless Steel Wall Shelf include the following parts. Please inspect box contents to ensure you have received all components.

If you are missing any parts, need assistance with assembly or have questions, please contact TRINITY Customer Service: 800.985.5506 or customerservice@trinityii.com. Parts can also be requested online via our "Contact Us" section at www.trinityii.com.

You will need a pencil, a Philips screwdriver, and a drill for assembly.

A



SHELF (1)

B

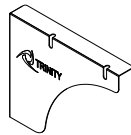

LEFT BRACKET (1)

C

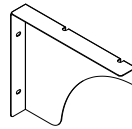

RIGHT BRACKET (1)

D



NUT (4)

E



WRENCH (1)

F

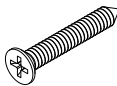

SCREW (4)

G



ANCHOR (4)

H



**WALL MOUNTING
TEMPLATE (1)**

ASSEMBLY INSTRUCTIONS

STEP 1

Two people are recommended for ease of assembly.

Place SHELF (A) upside down on a soft surface. Attach LEFT & RIGHT BRACKETS (B & C) to SHELF (A) as shown, making sure threaded studs on two inner sides of shelf fit into notches on LEFT & RIGHT BRACKETS (B & C). Fasten NUT (D) onto each threaded stud with provided WRENCH (E).

Note: LEFT BRACKET (B) has TRINITY logo embossed.

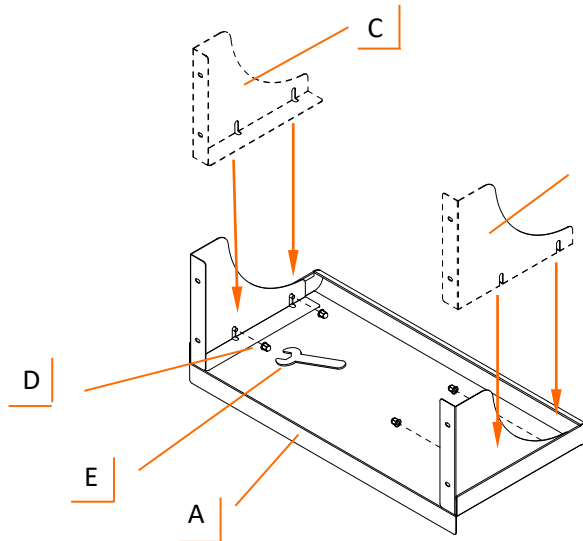
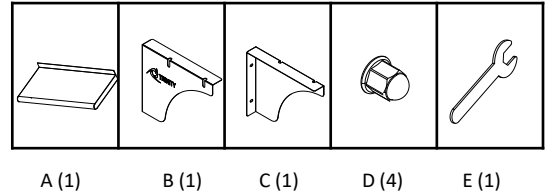

STEP 2

Place WALL MOUNTING TEMPLATE (H) against wall at your desired location. With a pencil, mark locations to install screws.

Notes:

*** Please consult a local contractor if you are unsure if your wall is able to bear the load of the wall shelf.**

**** Depending on wall mount requirement with or without anchors. Pre-drill appropriate size hole at each marked location.**

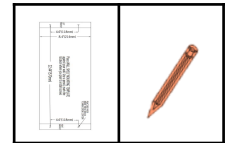

H (1)

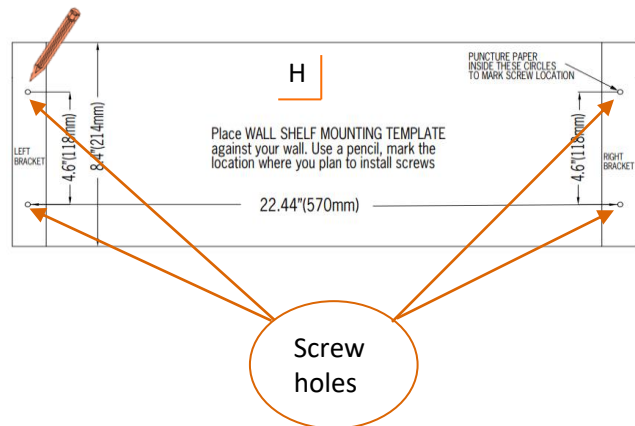

ASSEMBLY INSTRUCTIONS

STEP 3

If ANCHORS (G) are required, insert ANCHORS (G) completely into each drilled hole. Place assembly from step 1 to wall as shown. Align four holes on LEFT & RIGHT BRACKETS (B & C) to marked locations. Fasten SCREWS (F) through these holes into wall tightly with a Philips screwdriver.

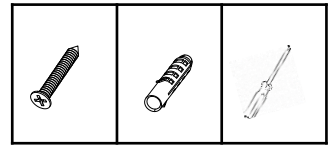

F (4)

G (4)

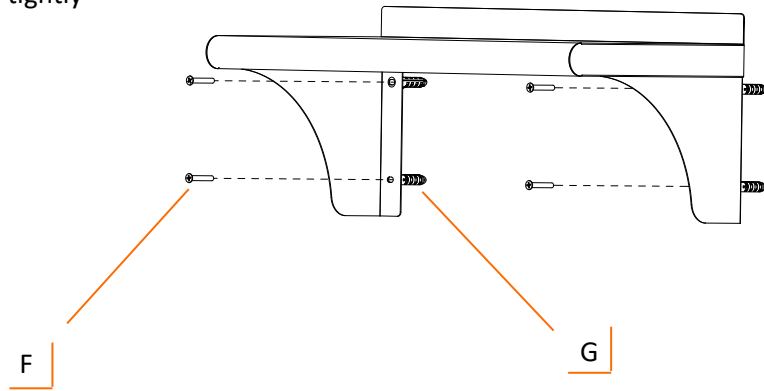

F

G

SERVICE PARTS LIST – THA-3328 / THA-33282 (2-pack)

TRINITY Customer Service provides the following replacement parts:

#	Part Number	Description	#	Part Number	Description
1)	XBS-03-103-2412	Shelf	5)	XWH-96-002-0003	Wall Mounting Template
2)	XBS-19-018-1025	Right Bracket	6)	XXX-97-002-0006	Wrench
3)	XGR-01-032-0837	Anchor	7)	ZNC-01-008-0608	Nut
4)	XSV-01-045-0538	Screw	8)	XBS-19-017-1025	Left Bracket

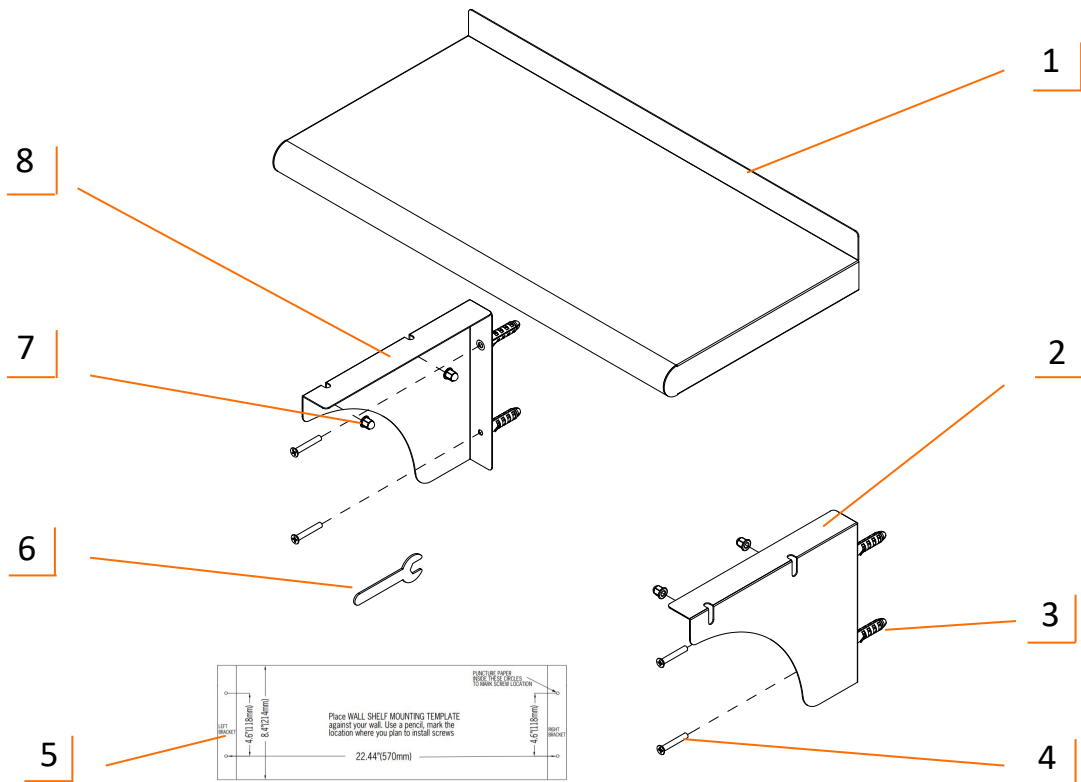

WARNINGS

1. **Read and understand all instructions.** Failure to follow all instructions may result in injury and/or damage.
2. **The warnings, cautions, and instructions discussed in this manual cannot cover all possible conditions or situations that may occur.** The user must always be aware of their environment and ensure that they use the product in a safe and responsible manner.
3. **Do NOT modify the product in any way.** Unauthorized modification may impair the function and/or safety of the product, and may affect the life of the product. Any modifications will void product warranty.
4. **Check for damaged parts.** Before using this product, carefully check that all parts are in good condition, and that the product will operate properly and perform its intended function. Check for damaged parts and any other conditions that may affect the operation of this product. Replace damaged or worn parts, and never use this product with a damaged part.
5. **Do NOT overload the product.** Each shelf holds up to 250lb with evenly distributed weight.
6. **Do NOT allow children to climb or hang on the shelf.**

CARE AND MAINTENANCE

- Avoid harsh, abrasive cleaners, and other corrosive chemicals. Do not leave salt on the shelf or near saltwater environment.
- Rinse surface thoroughly with hot water after using soaps and detergents containing chlorides to prevent corrosion.
- Do not use scouring pad, carbon steel brushes, or steel wool for cleaning. Iron particles left behind can lead to rust.
- Avoid the use of oily rags or greasy cloths when wiping the surface. Wipe dry after use so that water does not leave water spots.
- Use a quality stainless steel cleaner and follow instructions that come with the cleaner. Wipe ALONG the grain (NOT against).
- This product is designed for indoor use.



PRODUCT REGISTRATION

Thank you for purchasing a TRINITY EcoStorage® 24" Stainless Steel Wall Shelf. In order to register your product and receive streamlined customer service, please fill out the following Product Registration Form and (1) fax the form to 310.347.4134 (2) complete the Product Registration Form online at www.trinityii.com or (3) scan and email the form to customerservice@trinityii.com. Include a copy of your original receipt with your submission.

First Name: _____ Last Name: _____

Address: _____

City: _____ State: _____ Zip Code: _____

Email Address: _____ Phone: _____

Product Model #: _____ Purchase Date: ____ / ____ / ____

Location of Purchase: _____

Please rate the importance of each feature (1=least important; 10=most important)

Quality ____ Price ____ Size/Capacity ____ Appearance ____ Other ____

How did you hear about our product?

- Magazine Ad Catalog Salesperson Word of Mouth
 Internet Store Display Other

Marital Status: Single Married

Household Income: Below \$50,000 \$50,000-\$150,000 \$150,000+

Education: High School College Graduate School

Primary Residence: Own Rent

Comments/Suggestions:

1 YEAR LIMITED WARRANTY

NITY EcoStorage® 24" Stainless Steel Wall Shelf Model# THA-3328 / THA-33282 (2-pack)

Trinity International Industries ("Trinity") warrants to the original consumer purchaser ("Purchaser") of the TRINITY EcoStorage® 24" Stainless Steel Wall Shelf ("Product") that each Product shall be free from defects in workmanship and materials for a period of 1 year from the date of original purchase. Trinity's obligation under this warranty shall be limited to repair or replacement of, or adequate compensation for the Product which shall not be greater than the amount of the purchase price of the Product, at the option of Trinity, during the warranty period. All replaced parts and Products become the property of Trinity and must be returned to Trinity.

This warranty excludes normal wear and tear of the Product and its parts or components, and damage arising from any of the following: negligent use or misuse of the Product, use contrary to this User's Manual, or alteration by any one other than Trinity. The warranty period of 1 year shall not be extended or renewed by the repair or replacement of, or compensation for, the Product. Any warranty implied by applicable law is limited in duration to one year from the date of purchase and is subject to the same conditions and limitations as is provided for our express warranty.

Except as set forth herein, and to the extent of applicable there are no warranties on this Product either express or implied, and Trinity disclaims all warranties including, but not limited to, any implied warranties of merchantability, infringement or fitness for a particular purpose. No warranty or guarantee given by any person, firm, or corporation with respect to this product shall be binding on Trinity.

If your Product is defective or otherwise requires service or parts, please call TRINITY Customer Service toll-free at (800) 985-5506, between 5:00 a.m. and 5:00 p.m., PST. Please tell us which model you purchased, the date of the purchase, and the problem with your Product. A copy of your original purchase receipt must accompany your service request.

LIMITATION OF REMEDIES AND LIABILITY

Trinity (and its employees, officers, members, managers, affiliates and assigns) shall not be liable for any incidental, consequential, special, indirect, remote, special or punitive damages for breach of any warranty, express or implied, including, but not limited to, lost profits, lost savings, loss of anticipated benefits and attorneys' fees, which arise out of the purchase, use or inability to use the Product, whether arising out of contract, negligence, strict tort, product liability, or any other legal theory on which a claim is based. As noted above, to the extent damages are allowed by our express warranty or by applicable law, those damages may not exceed the purchase price paid for the Product. Without limiting the foregoing Purchaser assumes all risk and liability for loss, damage or injury to Purchaser and Purchaser's property and to others and their property arising out of the use, misuse, or inability to use this Product. This limited warranty shall not extend to anyone other than the original purchaser of this product, is nontransferable and states your exclusive remedy.

Some states do not allow the exclusion or limitation of incidental, consequential, special, or punitive damages, so the above limitation or exclusion may not apply to you. The above warranty gives you specific legal rights, and you may have other rights which vary from state to state.





CONTACT US

**QUESTIONS? NEED PARTS?
WE ARE HERE TO HELP!**

Please feel free to contact us. There are no questions too small, or any problems too big. We're committed to providing our customers with the highest level of service.

TRINITY Customer Service

TEL: 800.985.5506

FAX: 310.347.4134

EMAIL: customerservice@trinityii.com

**Monday through Friday
5:00 AM – 5:00 PM (PST)**

www.trinityii.com