

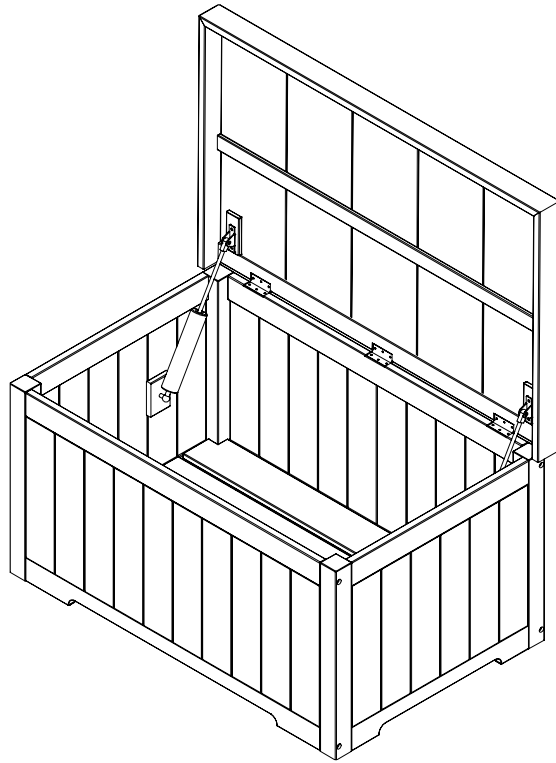

## OWNER'S MANUAL



### TRINITY ECOSTORAGE® 70 GALLON DECK BOX Model # THBAB-3108 / THBBR-3108 / THBGR-3108

Important / Important / Importante

FOR 3D ASSEMBLY INSTRUCTIONS  
POUR DES DIRECTIVES D'ASSEMBLAGE 3D  
PARA INSTRUCCIONES DE ENSAMBLAJE EN 3D



# BILT.®

Intelligent Instructions  
Directives intelligentes  
Instrucciones Inteligentes



# PARTS LIST

Your TRINITY EcoStorage® Deck Box should include the following parts. Please inspect box contents to ensure you have received all components.

If you are missing any parts, need assistance with assembly or have questions, please contact TRINITY Customer Service: 800.985.5506 or [customerservice@trinityii.com](mailto:customerservice@trinityii.com). Parts can also be requested online via our "Contact Us" section at [www.trinityii.com](http://www.trinityii.com).

Two people and a Phillips head screwdriver is recommended.

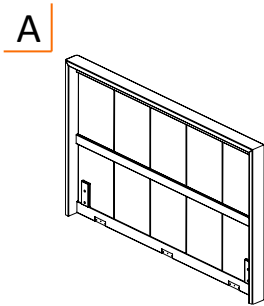

**LID (1)**

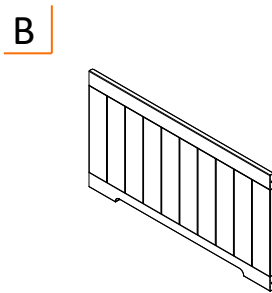

**FRONT PANEL (1)**

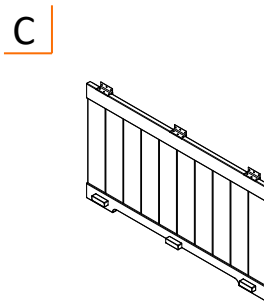

**BACK PANEL (1)  
W/ HINGES**

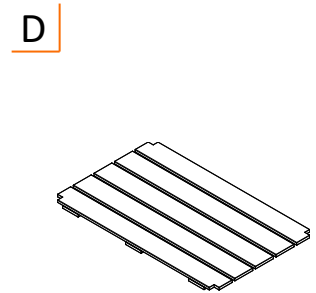

**BOTTOM (1)**

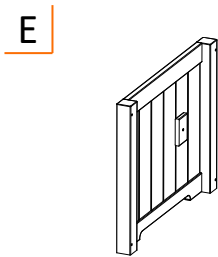

**LEFT SIDE  
PANEL (1)**

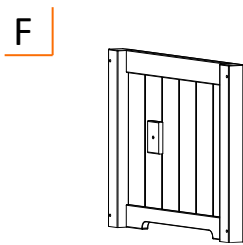

**RIGHT SIDE  
PANEL (1)**

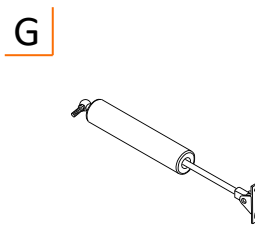

**GAS LIFT (2)**

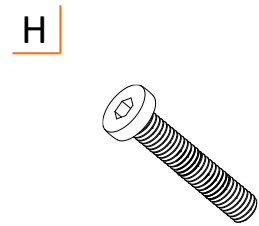

**SIDE PANEL  
SCREW (8)  
M6x60mm**

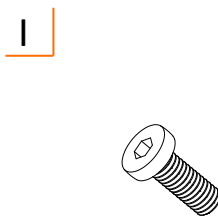

**GAS LIFT  
SCREW (4)  
M6x20mm**

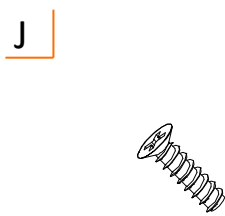

**HINGE  
SCREW (9)  
M4x20mm FLAT HEAD**

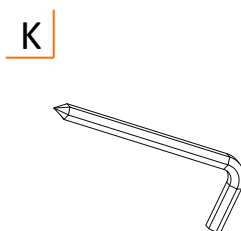

**HEX KEY (1)**



**WRENCH (1)**

# ASSEMBLY INSTRUCTIONS

## STEP 1

Align FRONT PANEL (B) with LEFT SIDE PANEL (E). Make sure notched edges are down and the LEFT SIDE PANEL (E) is positioned with the blocks facing in. Gas lift receiving nut should be away from the FRONT PANEL (B).

Insert SIDE PANEL SCREWS (H) through LEFT SIDE PANEL (E) and fasten them tightly to FRONT PANEL (B) with short end of HEX KEY (K).

Note: For ease of assembly, we recommended one person hold the FRONT PANEL (B) while a second person holds the LEFT SIDE PANEL (E).

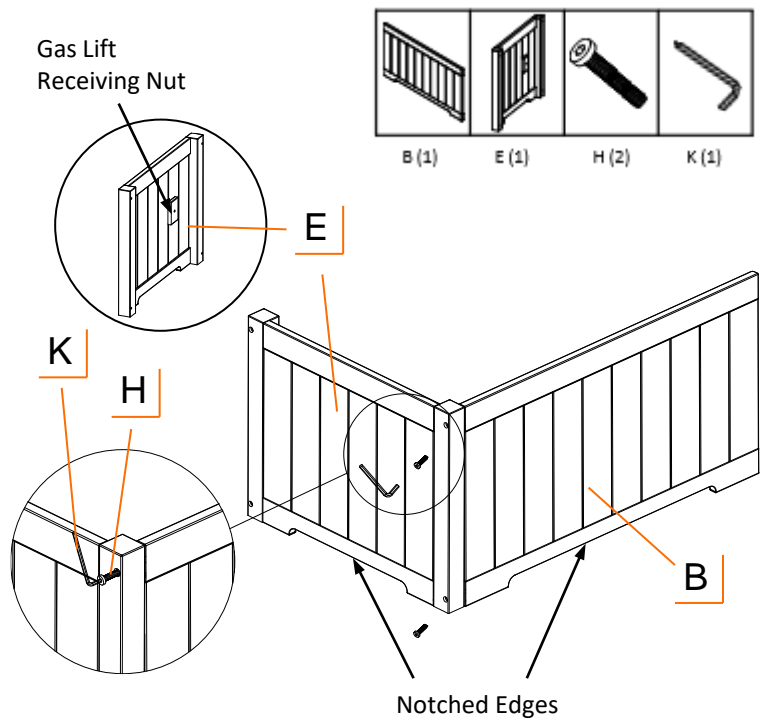

## STEP 2

Orient BACK PANEL (C) with hinges facing up. Make sure that the side with blocks is facing in. Align with LEFT SIDE PANEL (E).

Insert SIDE PANEL SCREWS (H) through LEFT SIDE PANEL (E) and fasten them tightly to BACK PANEL (C) with short end of HEX KEY (K).

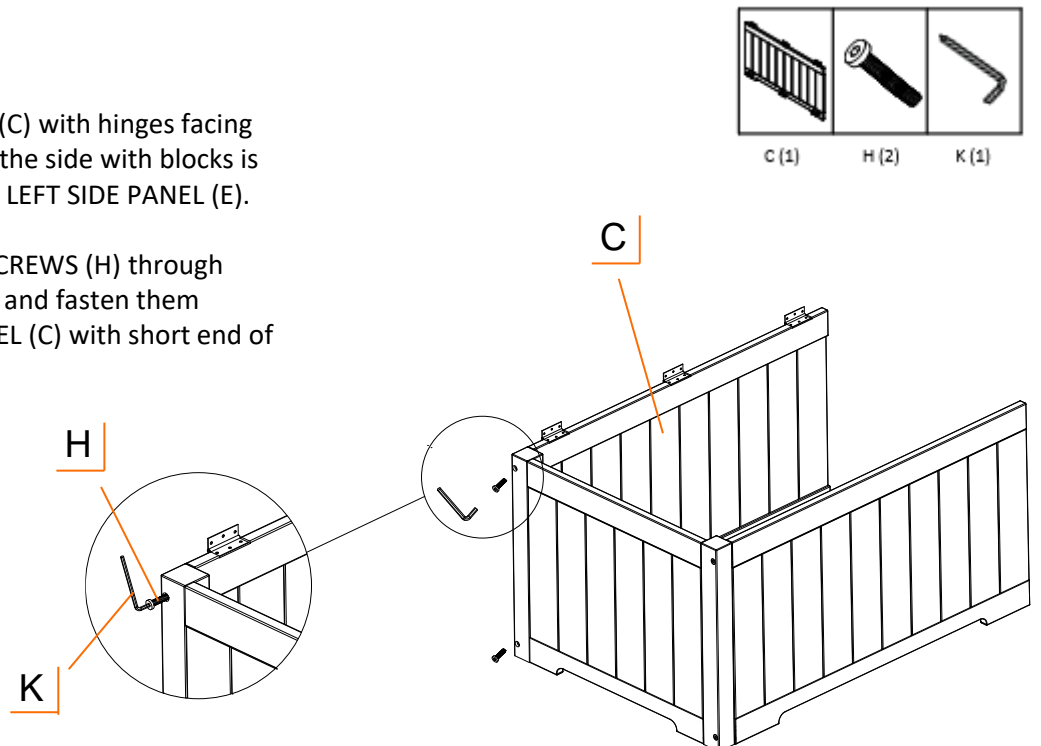

# ASSEMBLY INSTRUCTIONS

## STEP 3

Orient the RIGHT SIDE PANEL (F) with notched edge down and side with block facing in. Gas lift receiving nut should be closer to the BACK PANEL (C).

Insert SIDE PANEL SCREWS (H) through RIGHT SIDE PANEL (F) and fasten them tightly to FRONT PANEL (B) and BACK PANEL (C) with short end of HEX KEY (K).

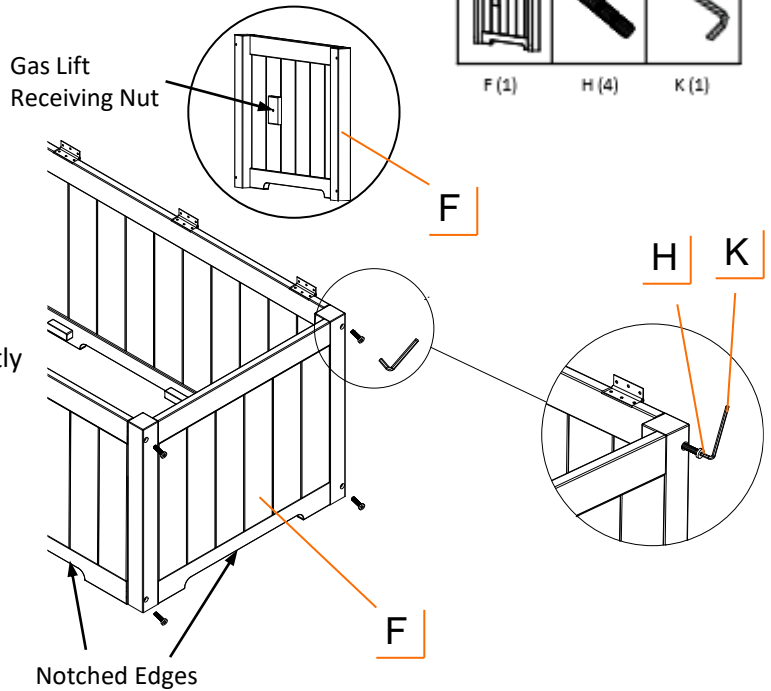

## STEP 4

Lay LID (A) on a clean surface with lip facing up. Carefully tip box to lay on BACK PANEL (C).

Align hinges with notches in LID (A). Insert HINGE SCREWS (J) through hinges and fasten them tightly to LID (A) with long end of HEX KEY (K).

Note: For ease of assembly, we recommend that one person lift the LID (A) so that the other person can align hinges on the LID (A) to the box to fasten the HINGE SCREWS (J).

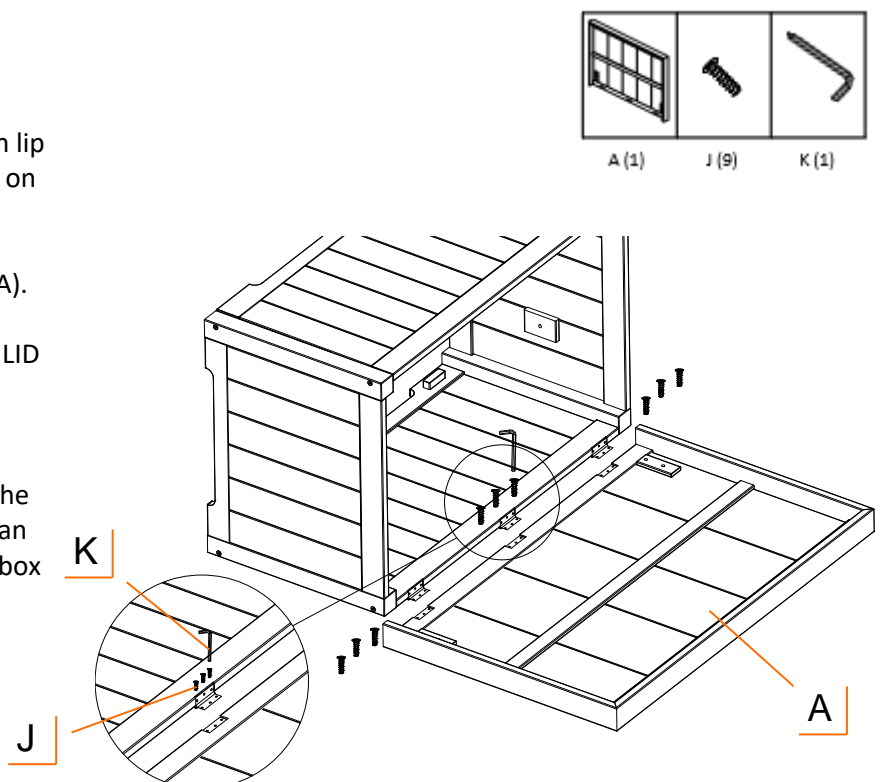

# ASSEMBLY INSTRUCTIONS

## STEP 5

Insert a GAS LIFT SCREW (I) first through the round hole of the fitting on GAS LIFT (G). Then insert the second GAS LIFT SCREW (I) through the slot of the fitting. Fasten tightly to LID (A) with short end of HEX KEY (K).

Do this for both GAS LIFTS (G).

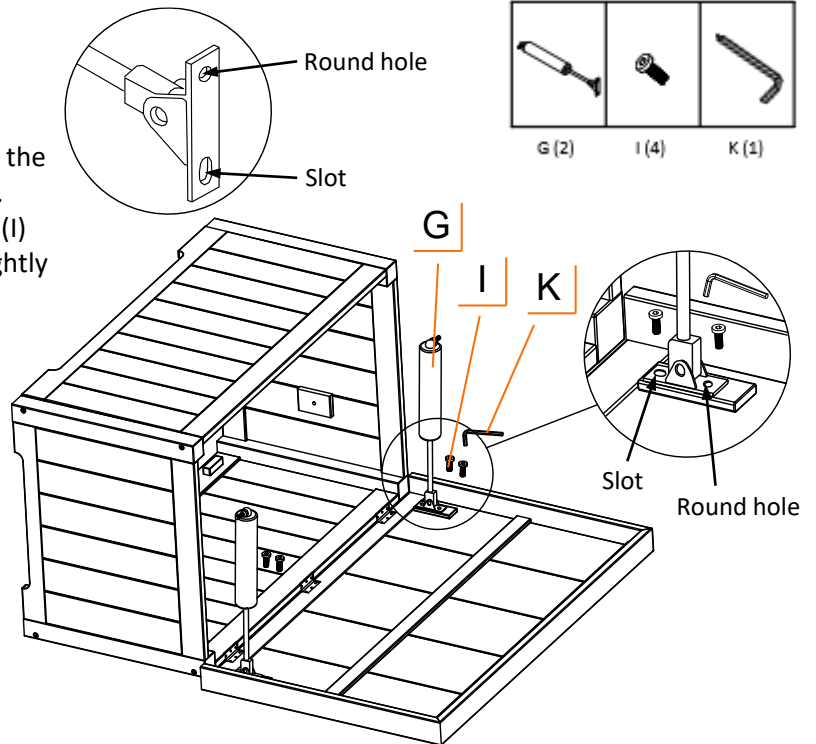

## STEP 6

Attach screw stud end of GAS LIFTS (G) to insert nuts on Side Panels and tighten with WRENCH (L).

If you are having trouble aligning the GAS LIFT'S (G) screw stud into the side panel, adjust the LID (A) up and down as needed.

Note: We recommend a second person help with this step by lifting the LID (A) to properly align GAS LIFT (G) screw stud end with insert nut on Side Panels so that it can be fully tightened.

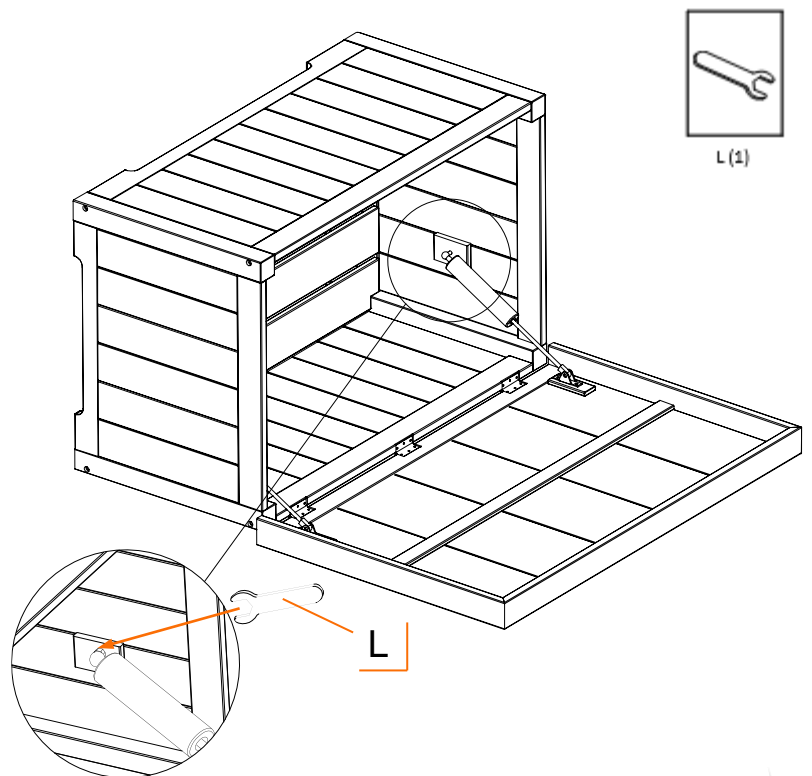

# ASSEMBLY INSTRUCTIONS

## STEP 7



Carefully set Deck Box upright.

Insert the BOTTOM (D) at an angle into the Deck Box from the front. Lower one end of BOTTOM (D) into the Deck Box first, making sure to clear the GAS LIFTS (G). Push BOTTOM (D) against the posts in the BACK PANEL (C) and lower it until that end is resting on the (3) support blocks.

Then, slowly lower the other end and gently drop the BOTTOM (D) and make sure it rests evenly on the supports on the FRONT PANEL (B).

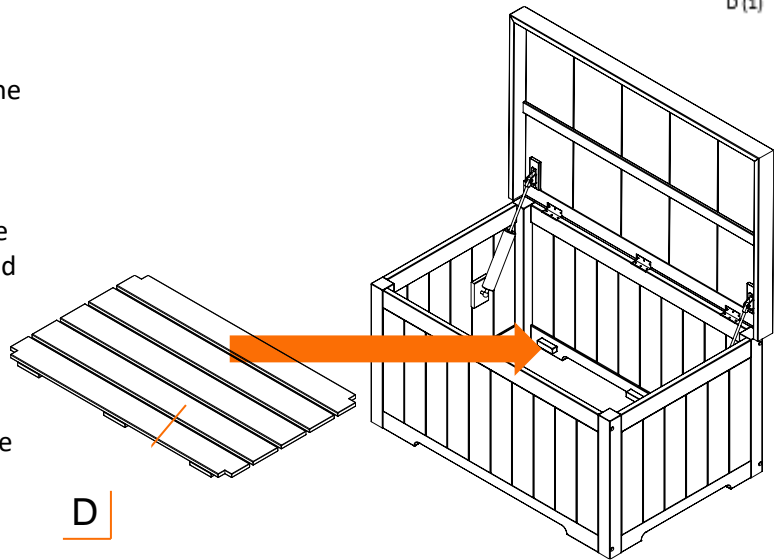

## SERVICE PARTS LIST

TRINITY Customer Service provides the following replacement parts:

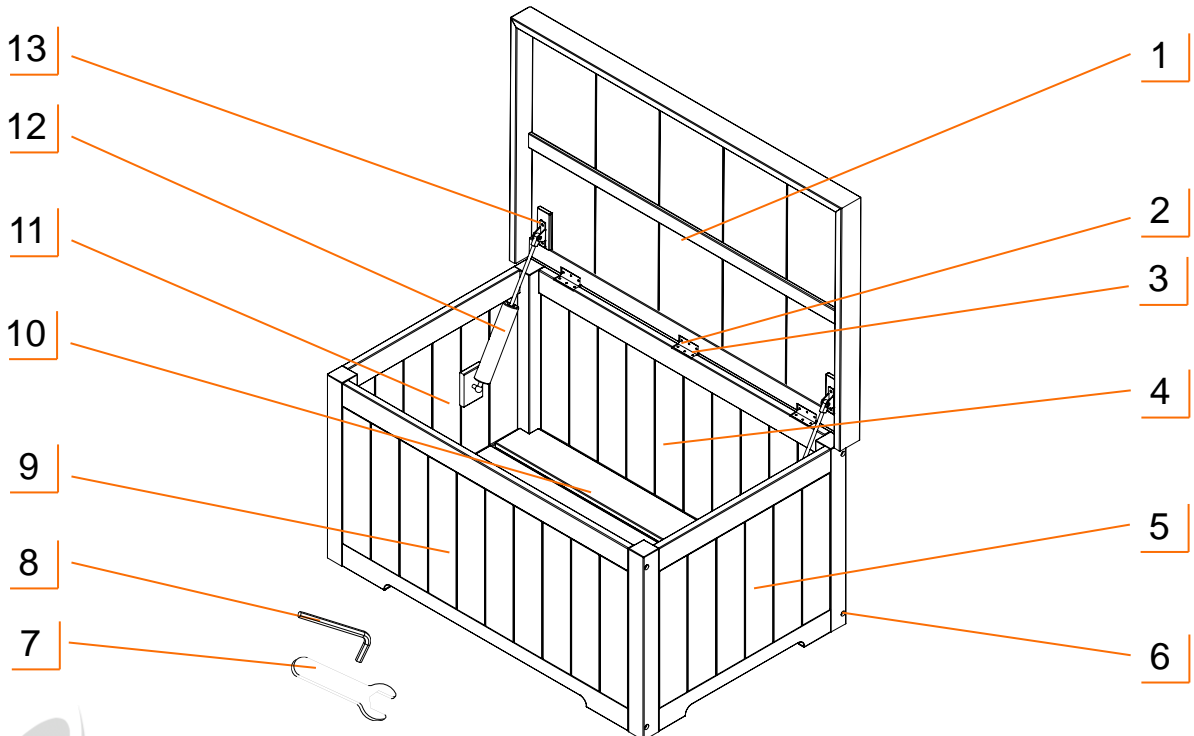

# SERVICE PARTS LIST

TRINITY Customer Service provides the following replacement parts:

## THBAB-3108 (AMBER BROWN)

	Part Number	Description		Part Number	Description
1)	XAB-17-007-4227	Lid	8)	XXX-97-001-0002	Hex Key
2)	XSV-09-009-0001	Hinge	9)	XAB-15-006-3620	Front Panel
3)	XSV-01-027-0420	Hinge Screw	10)	XAB-16-002-3824	Bottom
4)	XAB-15-007-3620	Back Panel	11)	XAB-14-016-2620	Left Side Panel
5)	XAB-14-017-2620	Right Side Panel	12)	PBK-09-008-0001	Gas Lift
6)	XSV-01-026-0660	Side Panel Screw	13)	XSV-01-026-0620	Gas Lift Screw
7)	XXX-97-002-0004	Wrench			

## THBBR-3108 (ESPRESSO BROWN)

	Part Number	Description		Part Number	Description
1)	XBR-17-007-4227	Lid	8)	XXX-97-001-0002	Hex Key
2)	XSV-09-009-0001	Hinge	9)	XBR-15-006-3620	Front Panel
3)	XSV-01-027-0420	Hinge Screw	10)	XBR-16-002-3824	Bottom
4)	XBR-15-007-3620	Back Panel	11)	XBR-14-016-2620	Left Side Panel
5)	XBR-14-017-2620	Right Side Panel	12)	PBK-09-008-0001	Gas Lift
6)	XSV-01-026-0660	Side Panel Screw	13)	XSV-01-026-0620	Gas Lift Screw
7)	XXX-97-002-0004	Wrench			

## THBGR-3108 (SLATE GRAY)

	Part Number	Description		Part Number	Description
1)	XGR-17-007-4227	Lid	8)	XXX-97-001-0002	Hex Key
2)	XSV-09-009-0001	Hinge	9)	XGR-15-006-3620	Front Panel
3)	XSV-01-027-0420	Hinge Screw	10)	XGR-16-002-3824	Bottom
4)	XGR-15-007-3620	Back Panel	11)	XGR-14-016-2620	Left Side Panel
5)	XGR-14-017-2620	Right Side Panel	12)	PBK-09-008-0001	Gas Lift
6)	XSV-01-026-0660	Side Panel Screw	13)	XSV-01-026-0620	Gas Lift Screw
7)	XXX-97-002-0004	Wrench			

---

## WARNINGS

1. **Read and understand all instructions.** Failure to follow all instructions may result in injury and/or damage.
2. **The warnings, cautions, and instructions discussed in this manual cannot cover all possible conditions or situations that may occur.** The user must always be aware of their environment and ensure that they use the product in a safe and responsible manner.
3. **Do NOT modify the product in any way.** Unauthorized modification may impair the function and/or safety of the product, and may affect the life of the product.
4. **Check for damaged parts.** Before using this product, carefully check that all parts are in good condition, and that the product will operate properly and perform its intended function. Check for damaged parts and any other conditions that may affect the operation of this product. Replace damaged or worn parts, and never use this product with a damaged part.
5. **Do NOT overload the product.**

Total weight capacity (evenly distributed)	250 lb
--	--------

6. **Do NOT let children climb or play in the Deck Box.**

---

## CARE AND MAINTENANCE

- Avoid harsh, abrasive cleaners, and other corrosive chemicals.
- Do not use metal scouring pad for cleaning. Most stains can be removed by using a mild soap and a soft-bristled brush.
- Avoid placing any direct heat source on or near the surface.
- Leaving any glassware on the Deck Box under sunlight may result in burn marks on the surface. Please use a coaster when placing glassware on the Deck Box.



# PRODUCT REGISTRATION

Thank you for purchasing a TRINITY EcoStorage® Deck Box. In order to register your product and receive streamlined customer service, please fill out the following Product Registration Form and (1) fax the form to 310.347.4134 (2) complete the Product Registration Form online at [www.trinityii.com](http://www.trinityii.com) or (3) scan and email the form to [customerservice@trinityii.com](mailto:customerservice@trinityii.com). Include a copy of your original receipt with your submission.

First Name: \_\_\_\_\_ Last Name: \_\_\_\_\_

Address: \_\_\_\_\_

City: \_\_\_\_\_ State: \_\_\_\_\_ Zip Code: \_\_\_\_\_

Email Address: \_\_\_\_\_ Phone: \_\_\_\_\_

Product Model #: \_\_\_\_\_ Purchase Date: \_\_\_\_ / \_\_\_\_ / \_\_\_\_

Location of Purchase: \_\_\_\_\_

Please rate the importance of each feature (1=least important; 10=most important)

Quality \_\_\_\_ Price \_\_\_\_ Size/Capacity \_\_\_\_ Appearance \_\_\_\_ Other \_\_\_\_

How did you hear about our product?

- Magazine Ad     Catalog     Salesperson     Word of Mouth  
 Internet     Store Display     Other

Marital Status:                       Single                                       Married

Household Income:                 Below \$50,000     \$50,000-\$150,000     \$150,000+

Education:                             High School             College             Graduate School

Primary Residence:                 Own                                       Rent

Comments/Suggestions:





# 1 YEAR LIMITED WARRANTY

## TRINITY EcoStorage® Deck Box Model # THBAB-3108/THBBR-3108/THBGR-3108

Trinity International Industries (“Trinity”) warrants to the original consumer purchaser (“Purchaser”) of the TRINITY EcoStorage® Deck Box (“Product”) that each Product shall be free from defects in workmanship and materials for a period of 1 year from the date of original purchase. Trinity’s obligation under this warranty shall be limited to repair or replacement of, or adequate compensation for the Product which shall not be greater than the amount of the purchase price of the Product, at the option of Trinity, during the warranty period. All replaced parts and Products become the property of Trinity and must be returned to Trinity.

This warranty excludes normal wear and tear of the Product and its parts or components, and damage arising from any of the following: negligent use or misuse of the Product, use contrary to this User’s Manual, or alteration by any one other than Trinity. The warranty period of 1 year shall not be extended or renewed by the repair or replacement of, or compensation for, the Product. Any warranty implied by applicable law is limited in duration to one year from the date of purchase and is subject to the same conditions and limitations as is provided for our express warranty.

Except as set forth herein, and to the extent of applicable there are no warranties on this Product either express or implied, and Trinity disclaims all warranties including, but not limited to, any implied warranties of merchantability, infringement or fitness for a particular purpose. No warranty or guarantee given by any person, firm, or corporation with respect to this product shall be binding on Trinity.

If your Product is defective or otherwise requires service or parts, please call TRINITY Customer Service toll-free at (800) 985-5506, between 8:00 a.m. and 5:00 p.m., PST. Please tell us which model you purchased, the date of the purchase, and the problem with your Product. A copy of your original purchase receipt must accompany your service request.

### LIMITATION OF REMEDIES AND LIABILITY

Trinity (and its employees, officers, members, managers, affiliates and assigns) shall not be liable for any incidental, consequential, special, indirect, remote, special or punitive damages for breach of any warranty, express or implied, including, but not limited to, lost profits, lost savings, loss of anticipated benefits and attorneys’ fees, which arise out of the purchase, use or inability to use the Product, whether arising out of contract, negligence, strict tort, product liability, or any other legal theory on which a claim is based. As noted above, to the extent damages are allowed by our express warranty or by applicable law, those damages may not exceed the purchase price paid for the Product. Without limiting the foregoing Purchaser assumes all risk and liability for loss, damage or injury to Purchaser and Purchaser’s property and to others and their property arising out of the use, misuse, or inability to use this Product. This limited warranty shall not extend to anyone other than the original purchaser of this product, is nontransferable and states your exclusive remedy.

Some states do not allow the exclusion or limitation of incidental, consequential, special, or punitive damages, so the above limitation or exclusion may not apply to you. The above warranty gives you specific legal rights, and you may have other rights which vary from state to state.

---

## CONTACT US

**QUESTIONS? NEED PARTS?  
WE ARE HERE TO HELP!**

Please feel free to contact us. There are no questions too small, or any problems too big. We're committed to providing our customers with the highest level of service.

### **TRINITY Customer Service**

**TEL: 800.985.5506**

**FAX: 310.347.4134**

**EMAIL: [customerservice@trinityii.com](mailto:customerservice@trinityii.com)**

**Monday through Friday  
5:00 AM – 5:00 PM (PST)**

**[www.trinityii.com](http://www.trinityii.com)**