

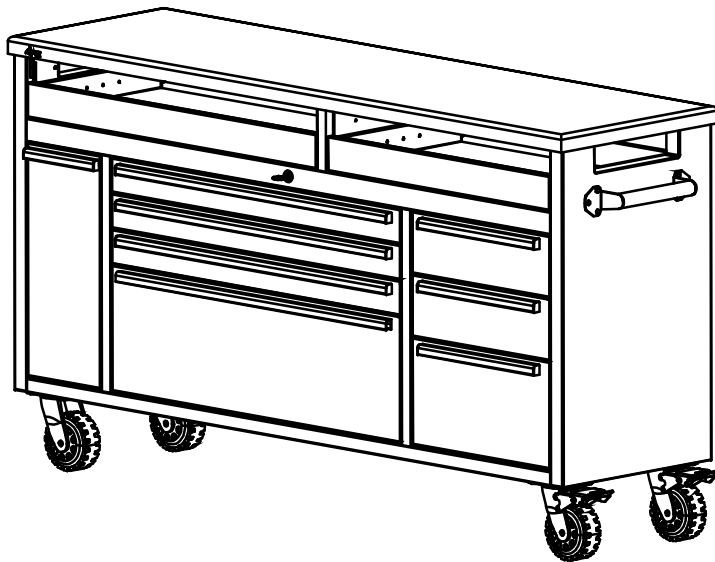

OWNER'S MANUAL



TRINITY PRO 66" STAINLESS STEEL ROLLING WORKBENCH W/CLAMPABLE RAISED TOP Model # TLSF-4811



Important / Important / Importante



FOR 3D ASSEMBLY INSTRUCTIONS
POUR DES DIRECTIVES D'ASSEMBLAGE 3D
PARA INSTRUCCIONES DE ENSAMBLAJE EN 3D

BILT.[®]

Intelligent Instructions
Directives intelligentes
Instrucciones Inteligentes



PARTS LIST

Your TRINITY PRO 66in Stainless Steel Rolling Workbench w/Clampable Raised Top should include the following parts. Please inspect box contents to ensure you have received all components.

If you are missing any parts, need assistance with assembly or have questions, please contact TRINITY Customer Service: 800.985.5506 or customerservice@trinityii.com. Parts can also be requested online via "Contact Us" section at www.trinityii.com.

You will need 10mm (for handles) and 14mm (for casters) socket wrenches for assembly which are NOT included.

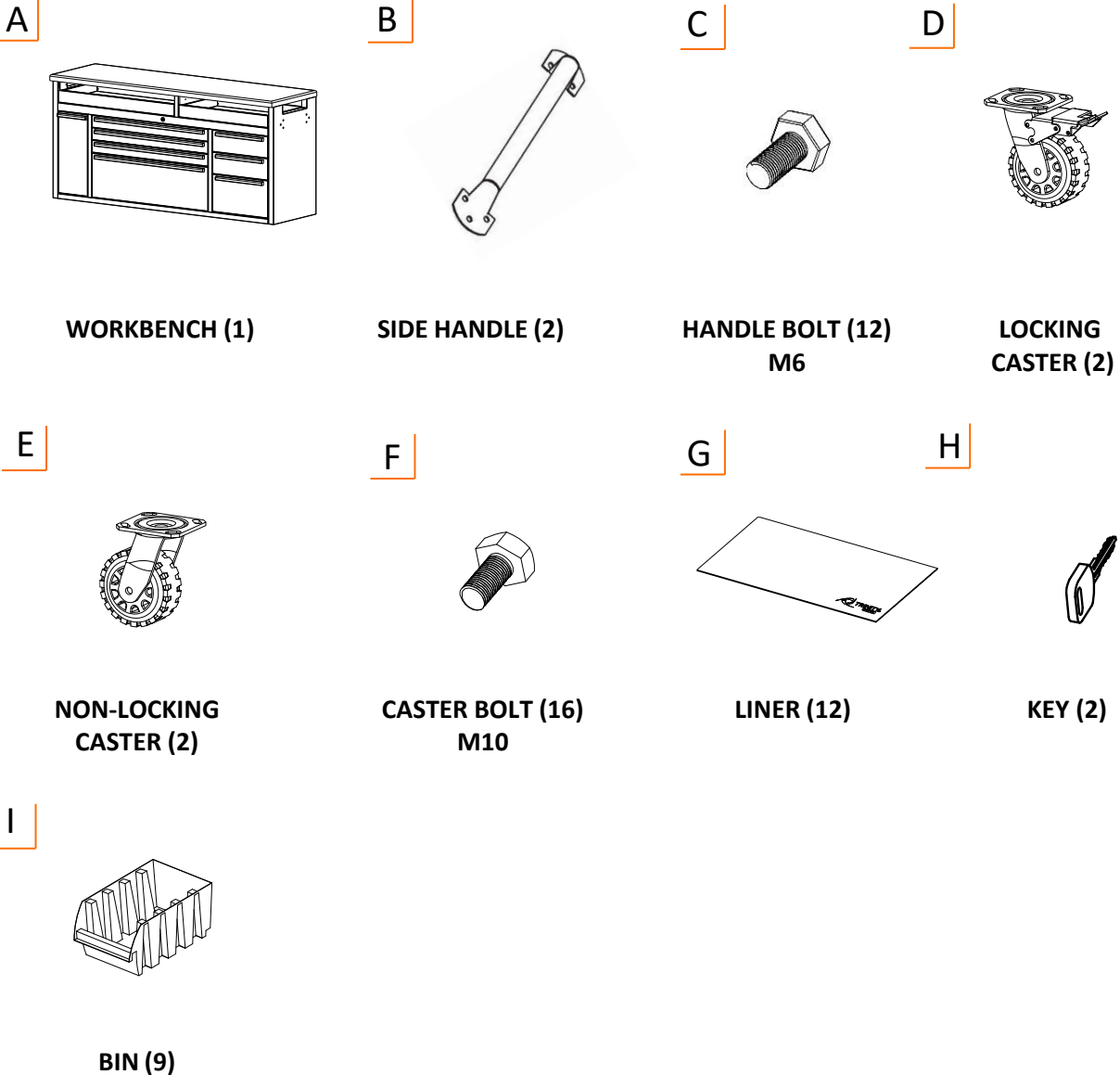

ASSEMBLY INSTRUCTIONS

STEP 1

Location of parts:

- 1) KEYS (H) are hooked to key leash mounted in top middle drawer.
- 2) SIDE HANDLES (B), HANDLE BOLTS (C), CASTERS (D/E), CASTER BOLTS (F), LINERS (G) and BINS (I) are inside accessory boxes in bottom middle drawer.

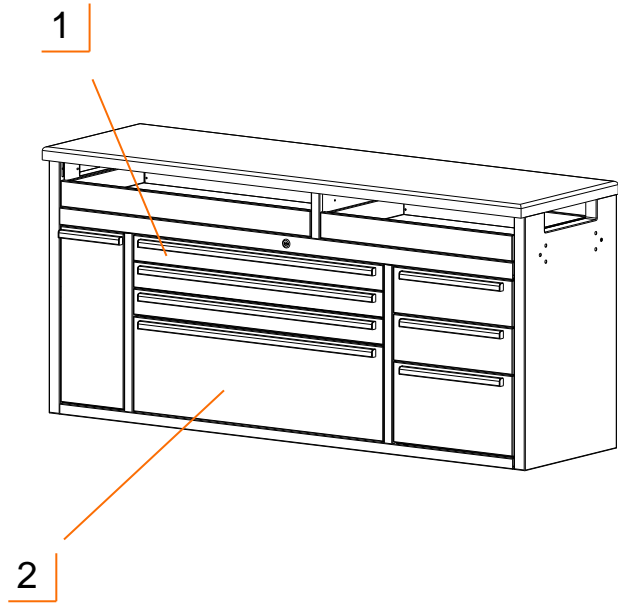

STEP 2

Position SIDE HANDLE (B) over pre-installed nuts on side of WORKBENCH (A). Insert HANDLE BOLTS (C) through holes on SIDE HANDLE (B). Use a 10mm socket wrench to fully tighten HANDLE BOLTS (C) to WORKBENCH (A).

Repeat to install other SIDE HANDLE (B).

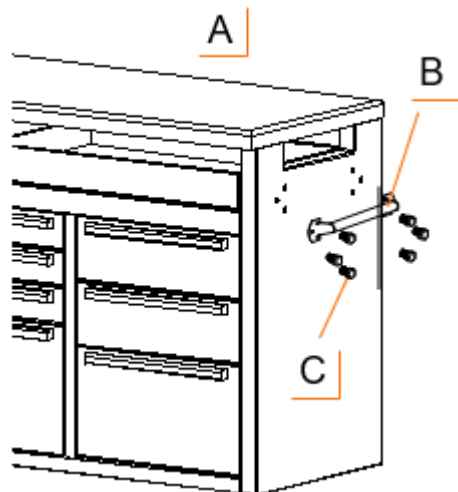
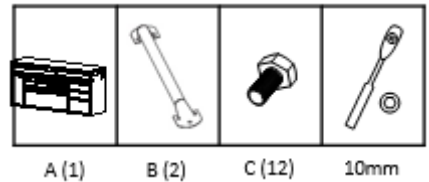

ASSEMBLY INSTRUCTIONS

STEP 3

Lay WORKBENCH (A) on its backside. Two people are needed. Do NOT attempt this alone.

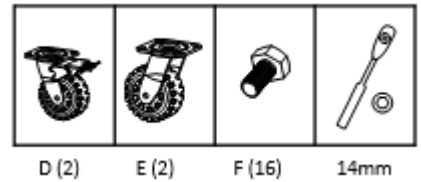

Position LOCKING CASTERS (D) on side of WORKBENCH (A) of your choice and align holes to pre-installed nuts on the underside of WORKBENCH (A). Use a 14mm socket wrench to fully tighten CASTER BOLT (F) to WORKBENCH (A).

Repeat to install NON-LOCKING CASTERS (E).

Notes:

- * Make sure to install both of LOCKING CASTERS (D) on same side.
- ** For ease of use, place LOCKING CASTERS (D) on side you will regularly push or pull.
- *** If you plan to push workbench against a wall, place LOCKING CASTERS (D) on front long side for ease of access.

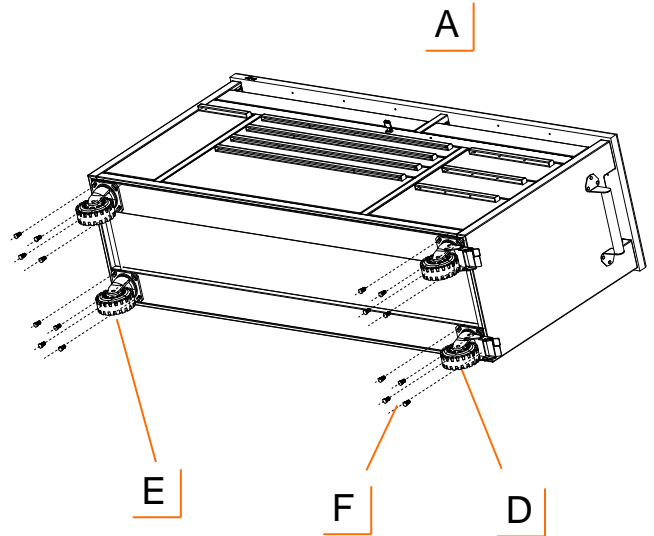

STEP 4

Place LINERS (G) in each pull-out tray and each drawer.

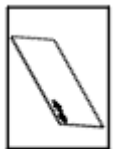

G (12)

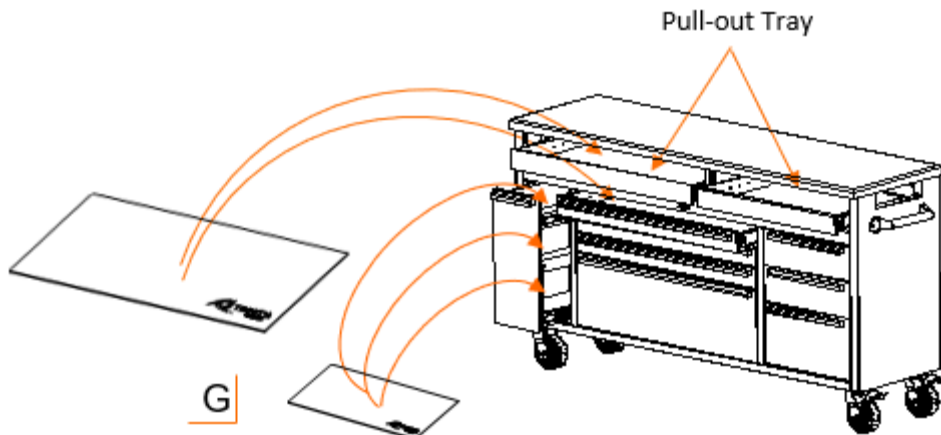

ASSEMBLY INSTRUCTIONS

STEP 5

Open Bin Drawer and hang 3 BINS (I) on each Shelf Side Panel as shown.



I (9)

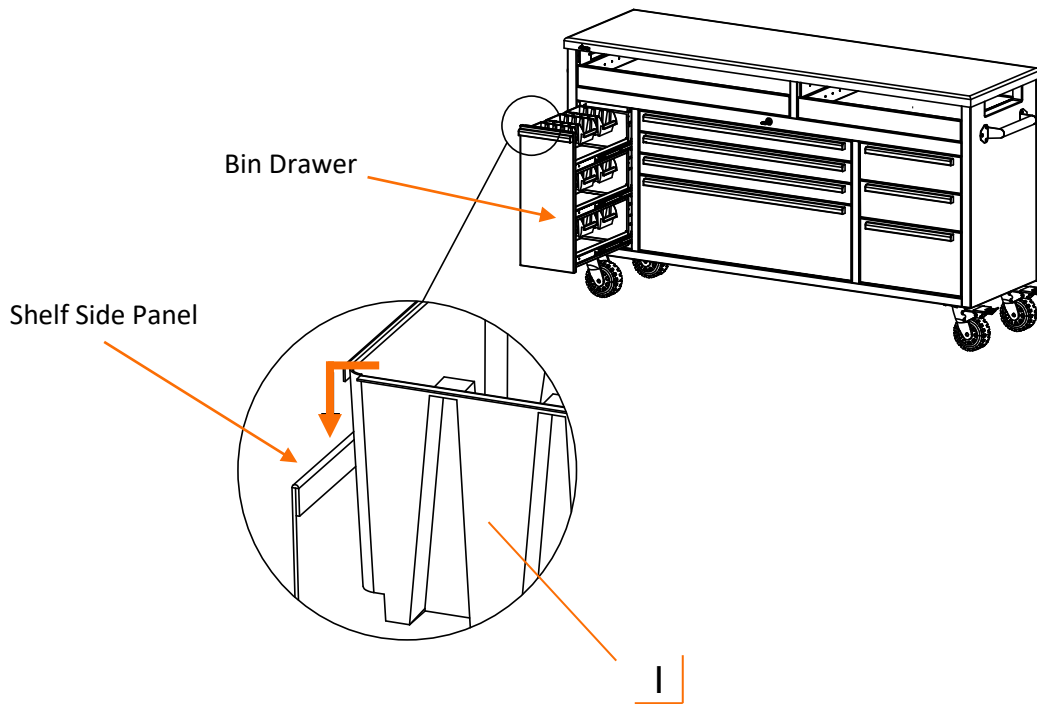

USAGE INSTRUCTIONS

DRAWER REMOVAL

Pull drawer out so that it is almost fully extended. On RIGHT-hand side, pull black release lever UP. On LEFT-hand side, push black release lever DOWN. While holding the levers as instructed, pull drawer forward until released from slides attached to Workbench (“Workbench Slides”).

Note: Slides attached to drawer (“Drawer Slides”) are an integral part of drawer and must be removed along with drawer itself.

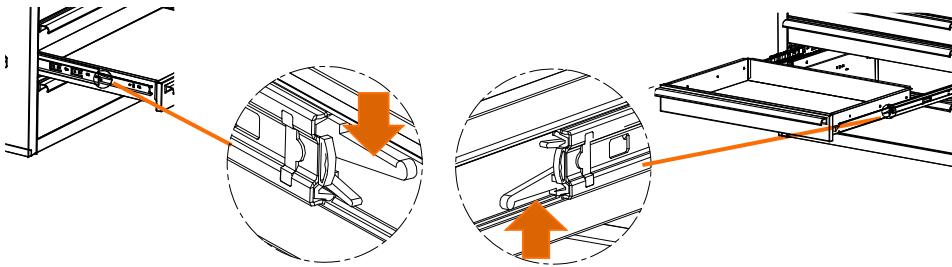

DRAWER REPLACEMENT

To replace drawer, pull slides out completely. Insert brackets on each side of Drawer Slides into corresponding slots on Workbench Slides, making sure they are properly positioned. Once brackets are inserted into slots, completely close drawer to set all slides in their proper positions.

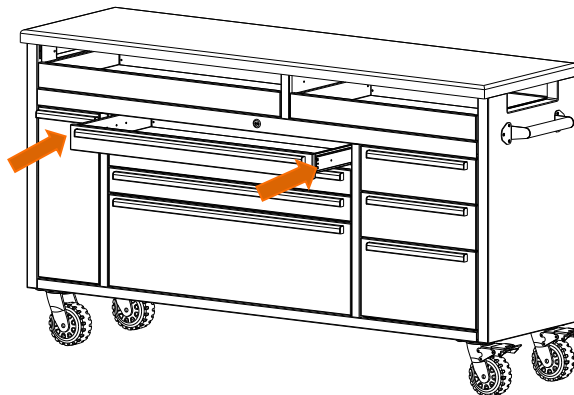

SERVICE PARTS LIST – TLSF-4811

TRINITY Customer Service provides the following replacement parts:

Part Number	Description	Part Number	Description
1) LNA-06-020-6619	Wood Top	14) XBK-22-006-1516	16" Drawer Liner
2) XBS-07-017-2603	26" Pull-out Tray	15) XBK-22-006-2516	26" Drawer Liner
3) ZSV-01-001-0612	Handle Bolt	16) XBK-22-006-3316	34" Drawer Liner
4) XSV-05-001-0900	Side Handle	17) ZSV-99-028-5020	Non-locking Caster
5) AMA-05-007-1500	16" Drawer Handle	18) XBS-07-009-3411	34" Deep Drawer
6) XBS-07-009-1605	16" Shallow Drawer	19) XBS-07-018-0920	Bin Drawer
7) ZSV-12-015-1575	Slide (workbench side)	20) AMA-05-007-0800	Bin Drawer Handle
8) ZSV-12-001-1575	Slide (drawer side)	21) XOR-21-007-0403	Bin
9) AMA-05-007-3300	34" Drawer Handle	22) CSV-11-005-0XXX	Lock
10) XBS-07-009-3403	34" Shallow Drawer	23) XBS-07-017-3403	34" Pull-out Tray
11) XBS-07-009-1609	16" Deep Drawer	24) XBK-02-047-0001	Key leash
12) ZSV-01-001-1020	Caster Bolt	25) XBK-10-003-0XXX	Key
13) ZSV-99-027-5020	Locking Caster		

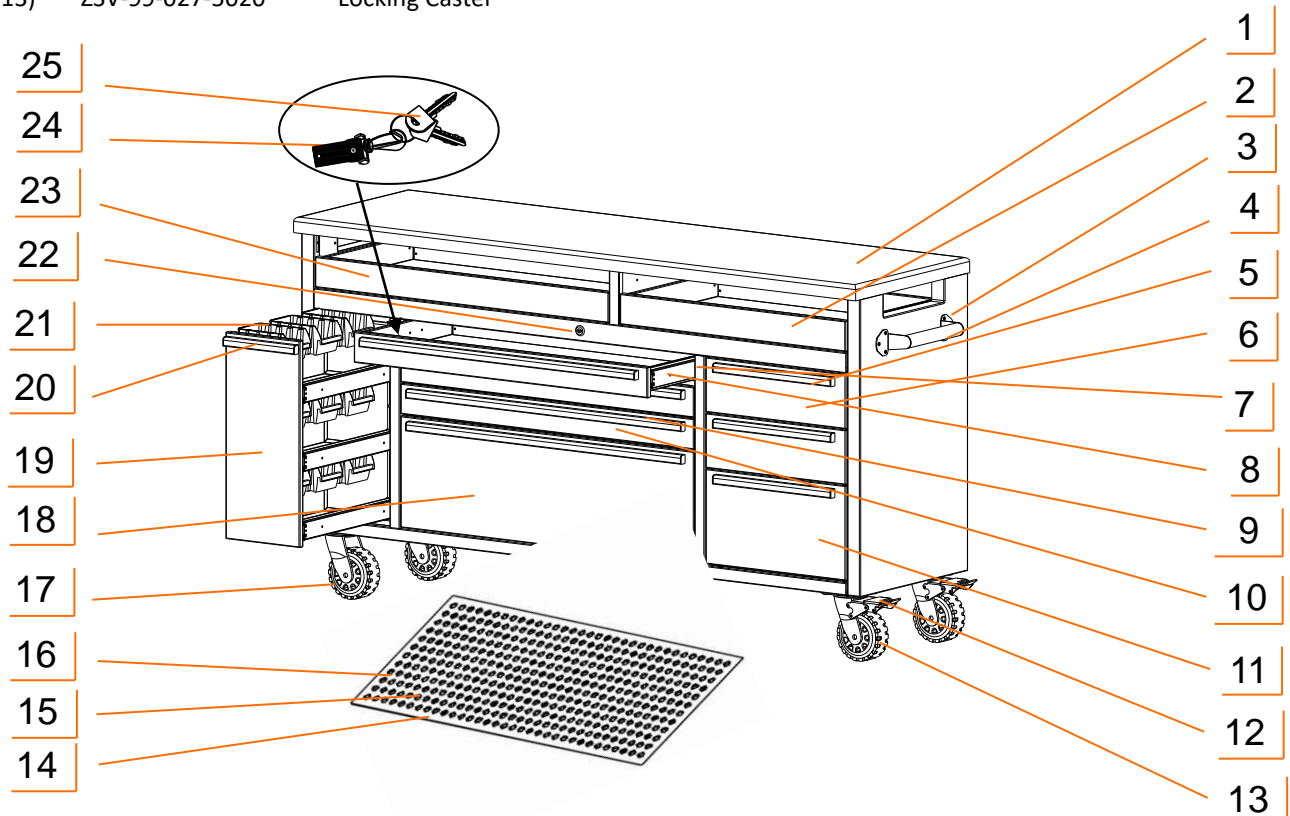

NOTE: Replacement keys may be ordered using the code shown on the face of the lock.

WARNINGS

1. **Read and understand all instructions.** Failure to follow all instructions may result in injury and/or damage.
2. **The warnings, cautions, and instructions discussed in this manual cannot cover all possible conditions or situations that may occur.** The user must always be aware of their environment and ensure that they use the product in a safe and responsible manner.
3. **Do NOT modify the product in any way.** Unauthorized modification may impair the function and/or safety of the product, and may affect the life of the product. Any modifications will void warranty.
4. **Check for damaged parts.** Before using this product, carefully check that all parts are in good condition, and that the product will operate properly and perform its intended function. Check for damaged parts and any other conditions that may affect the operation of this product. Replace damaged or worn parts, and never use this product with a damaged part.
5. **Do NOT overload the product.** Capacity is based on evenly distributed weight.

Weight capacity per bin	2 lb
Weight capacity per drawer w/ 1 pair of slides	100 lb
Weight capacity per drawer w/ 2 pairs of slides	200 lb
Total weight capacity of workbench	2200 lb

6. **Do NOT roll the product on an uneven surface.** Only move the product on a smooth surface. Rolling over rough or uneven surfaces may cause casters to break or items on the product to fall, resulting in injury and / or damage. Wood and laminate flooring can be scratched or dented. Ensure your flooring can bear the weight of loaded product before rolling loaded product across your flooring.
7. **Lock casters when leaving workbench in stationary position.**
8. **Lock drawers before moving the workbench.**
9. **Remove all items from wood top before moving the workbench.** Items may fall causing injury.
10. **Always move workbench with two people.** Roll slowly and constantly check surroundings to ensure enough clearance. Heavy weight workbench can be hard to stop if moving too fast, causing serious injury or damage.
11. **Do NOT open more than one drawer at a time.** Tipping can occur.
12. **Do NOT step or lean on open drawers.** Tipping can occur.



WARNINGS

13. **Do NOT lift workbench by wood top.** Wood top may separate causing injury.
14. **Do NOT hang on the wood top.** Tipping can occur.
15. **Do NOT let children play near the workbench.**
16. **Load workbench starting with bottom drawers to prevent workbench from tipping**
17. **Make sure all drawers are closed tightly before locking or unlocking.**

CARE AND MAINTENANCE

- Avoid harsh, abrasive cleaners, and other corrosive chemicals.
- Do not use scouring pad for cleaning.
- Keep dry and avoid damp environments.
- Use a quality stainless steel cleaner and follow instructions that come with the cleaner.
Wipe ALONG the grain (NOT against).
- Wood top can be cleaned with damp cloth and wiped dry immediately with dry cloth. If needed, solvent-based wood furniture cleaner can be used.
- Clean up any spills immediately to prevent stains from forming on the wood top.

PRODUCT REGISTRATION

Thank you for purchasing a TRINITY PRO 66in Stainless Steel Rolling Workbench w/Clampable Raised Top. In order to register your product and receive streamlined customer service, please fill out the following Product Registration Form and (1) fax the form to 310.347.4134 (2) complete the Product Registration Form online at www.trinityii.com or (3) scan and email the form to customerservice@trinityii.com. Include a copy of your original receipt with your submission.

First Name: _____ Last Name: _____

Address: _____

City: _____ State: _____ Zip Code: _____

Email Address: _____ Phone: _____

Product Model #: TLSF-4811 Purchase Date: ____ / ____ / ____

Location of Purchase: _____

Please rate the importance of each feature (1=least important; 10=most important)

Quality ____ Price ____ Size/Capacity ____ Appearance ____ Other ____

How did you hear about our product?

- Magazine Ad Catalog Salesperson Word of Mouth
 Internet Store Display Other

Marital Status: Single Married

Household Income: Below \$50,000 \$50,000-\$150,000 \$150,000+

Education: High School College Graduate School

Primary Residence: Own Rent

Comments/Suggestions:



1 YEAR LIMITED WARRANTY

TRINITY PRO 66" Stainless Steel Rolling Workbench w/Clampable Raised Top Model # TLSF-4811

Trinity International Industries ("Trinity") warrants to the original consumer purchaser ("Purchaser") of the TRINITY PRO 66in Stainless Steel Rolling Workbench w/Clampable Raised Top ("Product") that each Product shall be free from defects in workmanship and materials for a period of 1 year from the date of original purchase. Trinity's obligation under this warranty shall be limited to repair or replacement of, or adequate compensation for the Product which shall not be greater than the amount of the purchase price of the Product, at the option of Trinity, during the warranty period. All replaced parts and Products become the property of Trinity and must be returned to Trinity.

This warranty excludes normal wear and tear of the Product and its parts or components, and damage arising from any of the following: negligent use or misuse of the Product, use contrary to this User's Manual, or alteration by any one other than Trinity. The warranty period of 1 year shall not be extended or renewed by the repair or replacement of, or compensation for, the Product. Any warranty implied by applicable law is limited in duration to one year from the date of purchase and is subject to the same conditions and limitations as is provided for our express warranty.

Except as set forth herein, and to the extent of applicable there are no warranties on this Product either express or implied, and Trinity disclaims all warranties including, but not limited to, any implied warranties of merchantability, infringement or fitness for a particular purpose. No warranty or guarantee given by any person, firm, or corporation with respect to this product shall be binding on Trinity.

If your Product is defective or otherwise requires service or parts, please call TRINITY Customer Service toll-free at (800) 985-5506, between 5:00 a.m. and 5:00 p.m., PST. Please tell us which model you purchased, the date of the purchase, and the problem with your Product. A copy of your original purchase receipt must accompany your service request.

LIMITATION OF REMEDIES AND LIABILITY

Trinity (and its employees, officers, members, managers, affiliates and assigns) shall not be liable for any incidental, consequential, special, indirect, remote, special or punitive damages for breach of any warranty, express or implied, including, but not limited to, lost profits, lost savings, loss of anticipated benefits and attorneys' fees, which arise out of the purchase, use or inability to use the Product, whether arising out of contract, negligence, strict tort, product liability, or any other legal theory on which a claim is based. As noted above, to the extent damages are allowed by our express warranty or by applicable law, those damages may not exceed the purchase price paid for the Product. Without limiting the foregoing Purchaser assumes all risk and liability for loss, damage or injury to Purchaser and Purchaser's property and to others and their property arising out of the use, misuse, or inability to use this Product. This limited warranty shall not extend to anyone other than the original purchaser of this product, is nontransferable and states your exclusive remedy.

Some states do not allow the exclusion or limitation of incidental, consequential, special, or punitive damages, so the above limitation or exclusion may not apply to you. The above warranty gives you specific legal rights, and you may have other rights which vary from state to state.

CONTACT US

**QUESTIONS? NEED PARTS?
WE ARE HERE TO HELP!**

Please feel free to contact us. There are no questions too small, or any problems too big. We're committed to providing our customers with the highest level of service.

TRINITY Customer Service

TEL: 800.985.5506

FAX: 310.347.4134

EMAIL: customerservice@trinityii.com

**Monday through Friday
5:00 AM – 5:00 PM (PST)**

www.trinityii.com