



OWNER'S MANUAL



TRINITY PRO 72" STAINLESS STEEL ROLLING WORKBENCH W/ ADJUSTABLE TOP Model # TLSF-7211



Important / Important / Importante



FOR QUICK & EASY 3D ASSEMBLY INSTRUCTIONS

POUR DES DIRECTIVES D'ASSEMBLAGE 3D RAPIDES ET FACILES

PARA INSTRUCCIONES DE ENSAMBLAJE RÁPIDAS Y SENCILLAS EN 3D

BILT.[®]

Intelligent Instructions
Directives intelligentes
Instrucciones Inteligentes



DOWNLOAD THE FREE APP | TÉLÉCHARGER L'APPLICATION GRATUITE | DESCARGUE LA APLICACIÓN GRATUITA

PARTS LIST

Your TRINITY PRO 72in Stainless Steel Rolling Workbench w/ Adjustable Top should include the following parts. Please inspect box contents to ensure you have received all components.

If you are missing any parts, need assistance with assembly or have questions, please contact TRINITY Customer Service: 800.985.5506 or customerservice@trinityii.com. Parts can also be requested online via "Contact Us" section at www.trinityii.com.

You will need 14mm wrench for caster assembly which is NOT included.

A

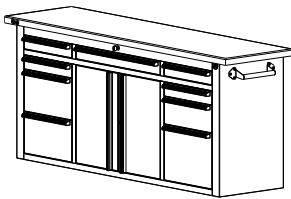

**WORKBENCH
w/Adjustable top (1)**

B

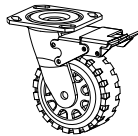

**LOCKING
CASTER (2)**

C



**NON-LOCKING
CASTER (2)**

D



**CASTER
BOLT (16)**

E

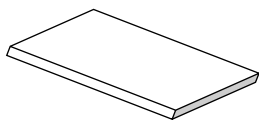

SHELF (1)

F



SHELF SUPPORT (4)

G

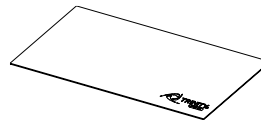

LINER (11)

H



KEY (4)

I



CRANK (1)

J



STOPPER (1)

ASSEMBLY INSTRUCTIONS

STEP 1

Location of parts:

- 1) KEYS (H) are hooked to key leash mounted inside TOP MIDDLE Drawer.
- 2) LINERS (G) are inside BOTTOM RIGHT Drawer.
- 3) CASTERS (B/C), CASTER BOLTS (D), SHELF SUPPORTS (F), CRANK (I) and STOPPER (J) are boxed inside BOTTOM LEFT Drawer.
- 4) SHELF (E) is inside bottom Cabinet.

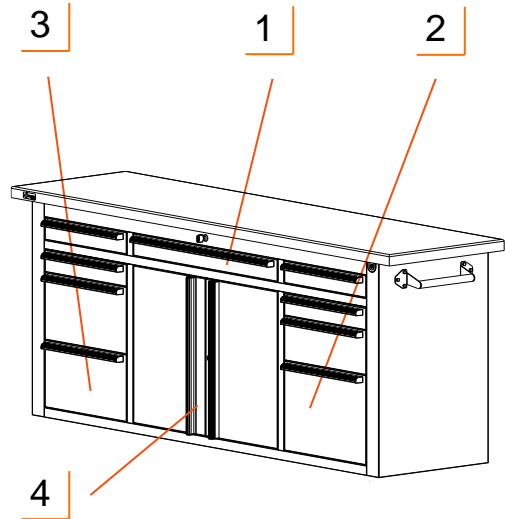

STEP 2

Lay WORKBENCH (A) on its backside. Lift workbench by side handles. Do NOT lift workbench by wood top. Two people are needed. Do NOT attempt this alone.

Position LOCKING CASTERS (B) on side of WORKBENCH (A) of your choice and align holes to pre-installed nuts on underside of WORKBENCH (A). Use a 14mm socket wrench to fully tighten CASTER BOLT (D) to WORKBENCH (A).

Repeat above steps to install NON-LOCKING CASTERS (C).

Notes:

- * Make sure to install both LOCKING CASTERS (B) on same side of workbench.
- ** For ease of use, place LOCKING CASTERS (B) on side you will regularly push or pull.
- *** If you plan to push workbench against a wall, place LOCKING CASTERS (B) on front long side for ease of access.

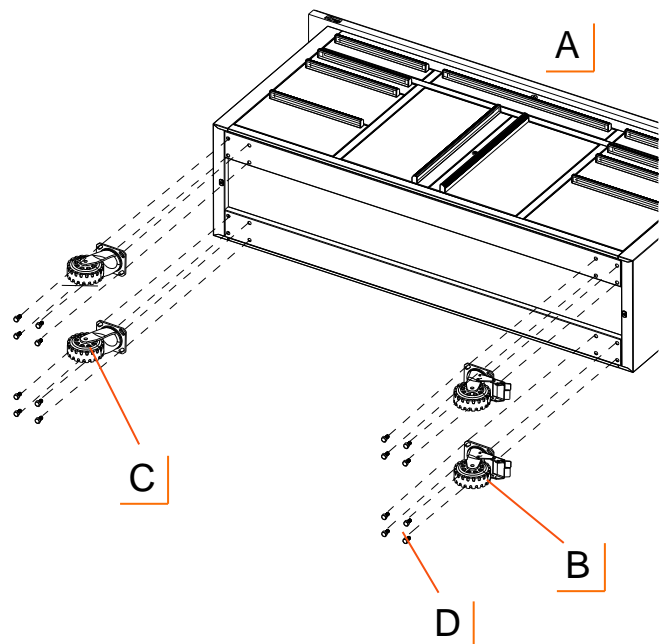
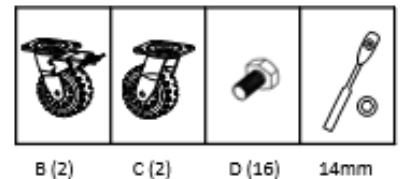

ASSEMBLY INSTRUCTIONS

STEP 3

Carefully lift Workbench upright. Two people are needed. Do NOT attempt this alone.

SHELF (E) is shipped inside the bottom cabinet. Tilt SHELF (E) diagonally and remove it from cabinet.

Attach SHELF SUPPORT (F) by hooking it over position tab at desired height. Make sure all four SHELF SUPPORTS (F) are at same level. Tilt SHELF (E) diagonally to move it inside cabinet. Place SHELF (E) on top of all four SHELF SUPPORTS (F).

You can adjust shelf height position by removing shelf, re-locating shelf supports and replacing shelf.

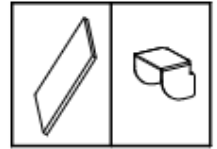

E (1) F (4)

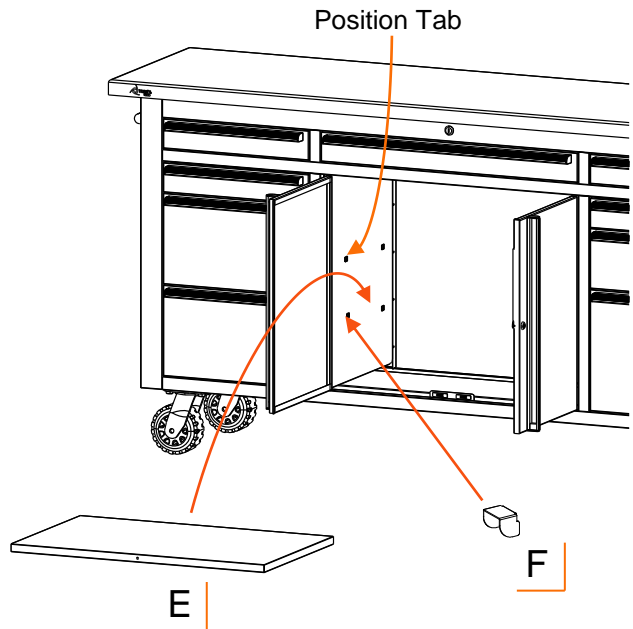

STEP 4

Place LINERS (G) inside each drawer and Cabinet.

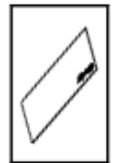

G (11)

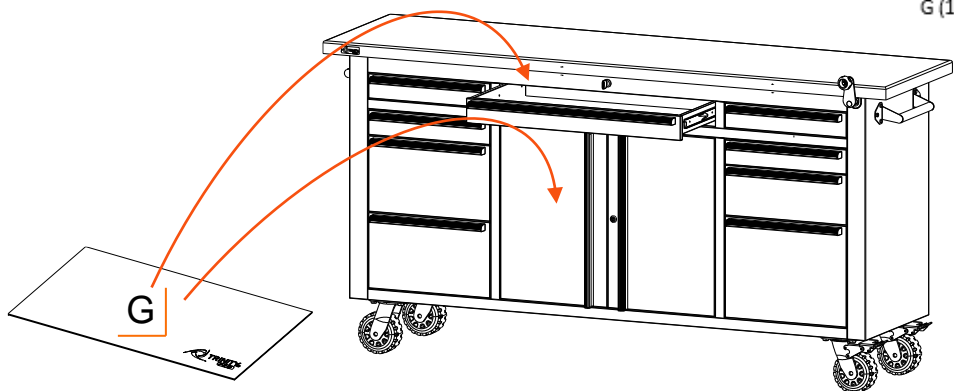

USAGE INSTRUCTIONS

ADJUST WOOD TOP

Insert CRANK (I) into receiver on Workbench.

Turn CRANK (I) **clockwise** to raise wood top. Turn CRANK (I) **counterclockwise** to lower wood top.

Remove CRANK (I) and store inside drawer after wood top is raised to desired position.



I (1)

Warnings:

- Remove all items from wood top before adjusting wood top height. Items falling from wood top during adjustment may cause injury.
- After adjusting wood top height, always install wood top STOPPER (J) to secure the height position.

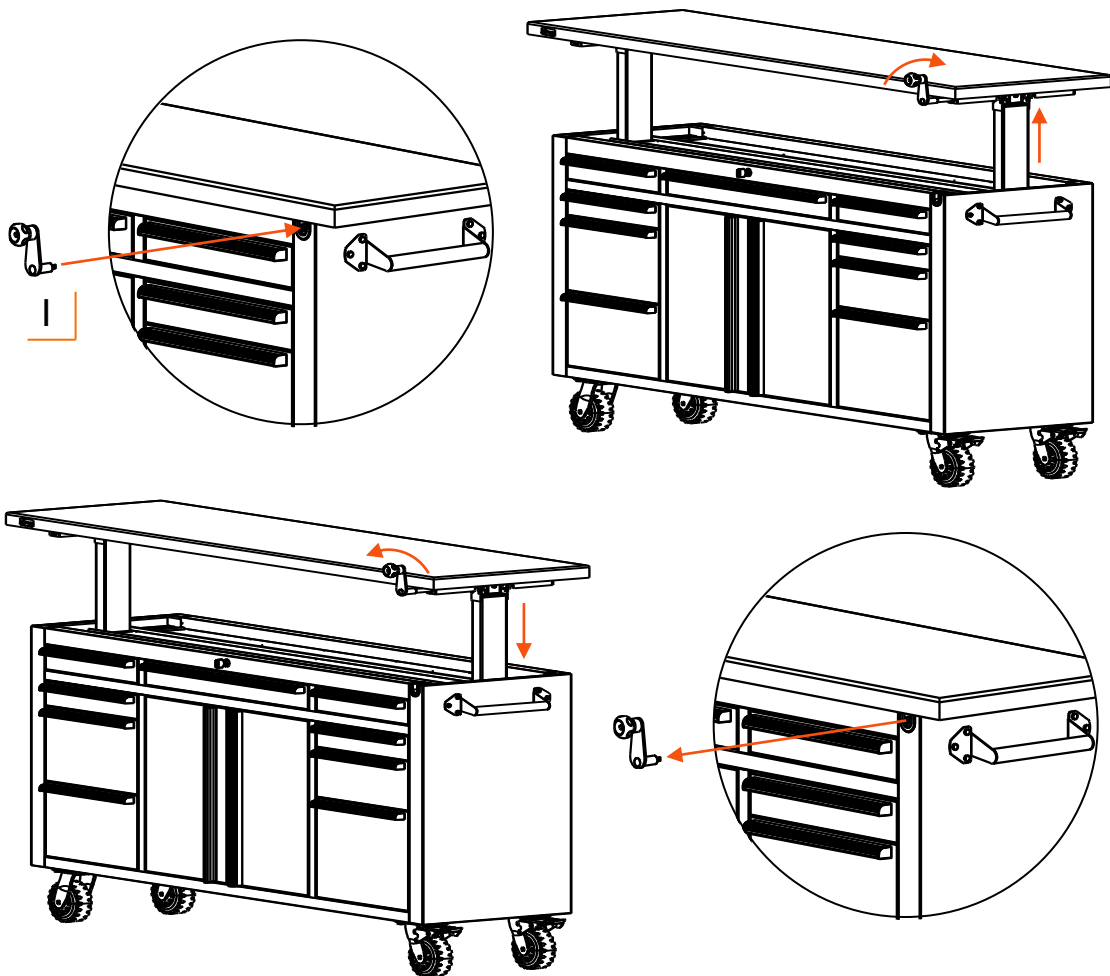

USAGE INSTRUCTIONS

INSTALL WOOD TOP STOPPER

Always install STOPPER (J) before utilizing raised wood top. Insert STOPPER (J) partially into receiver. Rotate to ensure STOPPER (J) is aligned to underside of wood top. Push STOPPER (J) fully into receiver under wood top. Ensure front of STOPPER (J) is flush with front of wood top.

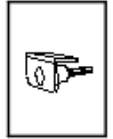

J (1)

If further height adjustment to wood top is desired, remove STOPPER (J) by pulling it out. Repeat adjust wood top step.

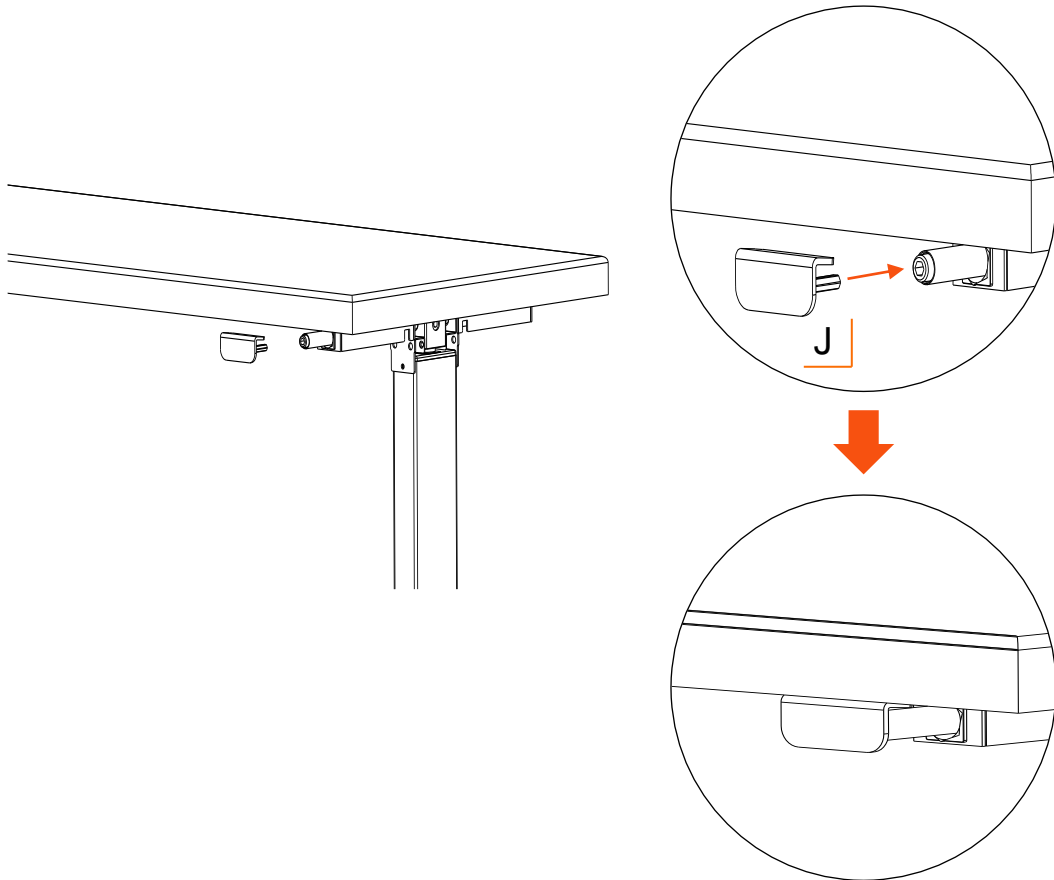

USAGE INSTRUCTIONS

DRAWER REMOVAL

Pull the drawer out so that it is almost fully extended. On the RIGHT-hand side, pull the black release lever UP. On the LEFT-hand side, push the black release lever DOWN. While holding the levers as instructed, pull the drawer forward until released from the slides attached to the Workbench (“Workbench Slides”).

Note: The slides attached to the drawer (“Drawer Slides”) are an integral part of the drawer and must be removed along with the drawer itself.

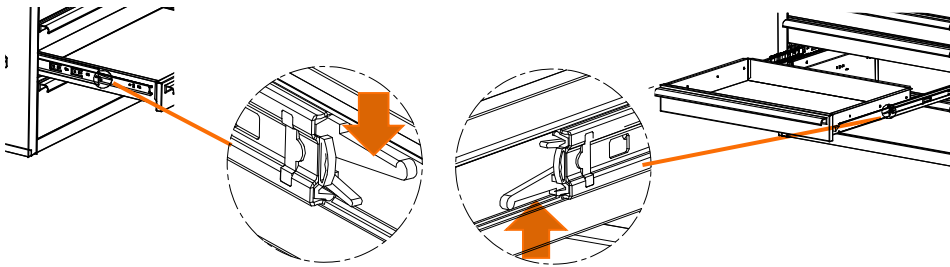

DRAWER REPLACEMENT

To replace the drawer, pull the slides out completely. Insert the brackets on each side of the Drawer Slides into the corresponding slots on the Workbench Slides, making sure they are properly positioned. Once the brackets are inserted into the slots, completely close the drawer to set all slides in their proper positions.

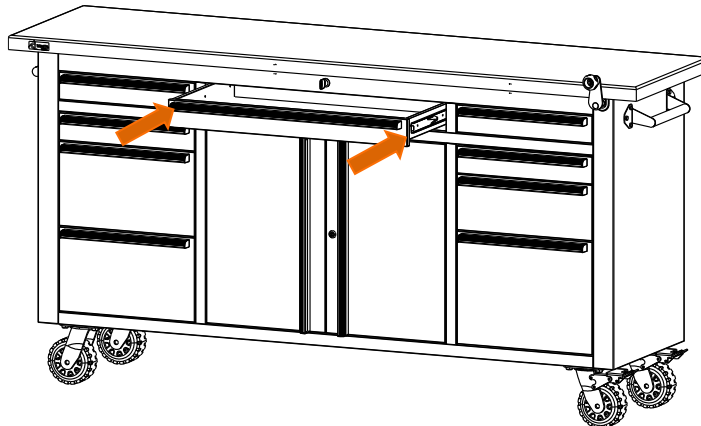

SERVICE PARTS LIST – TLSF-7211

TRINITY Customer Service provides the following replacement parts:

Part Number	Description	Part Number	Description
1) ZSV-12-015-1575	Slide (workbench side)	16) XBK-22-006-2615	27" Drawer Liner
2) ZSV-12-001-1575	Slide (drawer side)	17) XBK-22-006-1727	Shelf Liner
3) LNA-06-016-7219	Wood Top	18) XBS-08-017-1421	Right Door
4) XSV-05-029-0001	Crank	19) ZSV-99-028-5020	Non-locking Caster
5) EBK-05-031-0225	Stopper	20) AMA-05-007-2000	Door Handle
6) XSV-05-001-0900	Side Handle	21) XBS-07-009-1509	15" 2 nd Medium Drawer
7) ZSV-01-001-0612	Handle Bolt	22) XBK-23-010-3012	End cap
8) XBS-07-009-1506	15" 1 st Medium Drawer	23) XBS-07-009-1503	15" Small Drawer
9) XBS-07-009-1512	15" Large Drawer	24) AMA-05-007-1400	15" Drawer Handle
10) ZSV-99-027-5020	Locking Caster	25) XBS-07-009-2703	27" Drawer
11) ZSV-01-001-1020	Caster Bolt	26) AMA-05-007-2600	27" Drawer Handle
12) XBS-08-016-1421	Right Door	27) CSV-11-005-0XXX	Lock
13) XSV-02-017-0001	Shelf Support	28) XBK-02-047-0001	Key leash
14) PBK-03-084-2615	Shelf	29) XBK-10-003-0XXX	Key
15) XBK-22-006-1415	15" Drawer Liner		



SERVICE PARTS LIST – TLSF-7211

TRINITY Customer Service provides the following replacement parts:

NOTE: Replacement keys may be ordered using the code shown on the face of the lock.

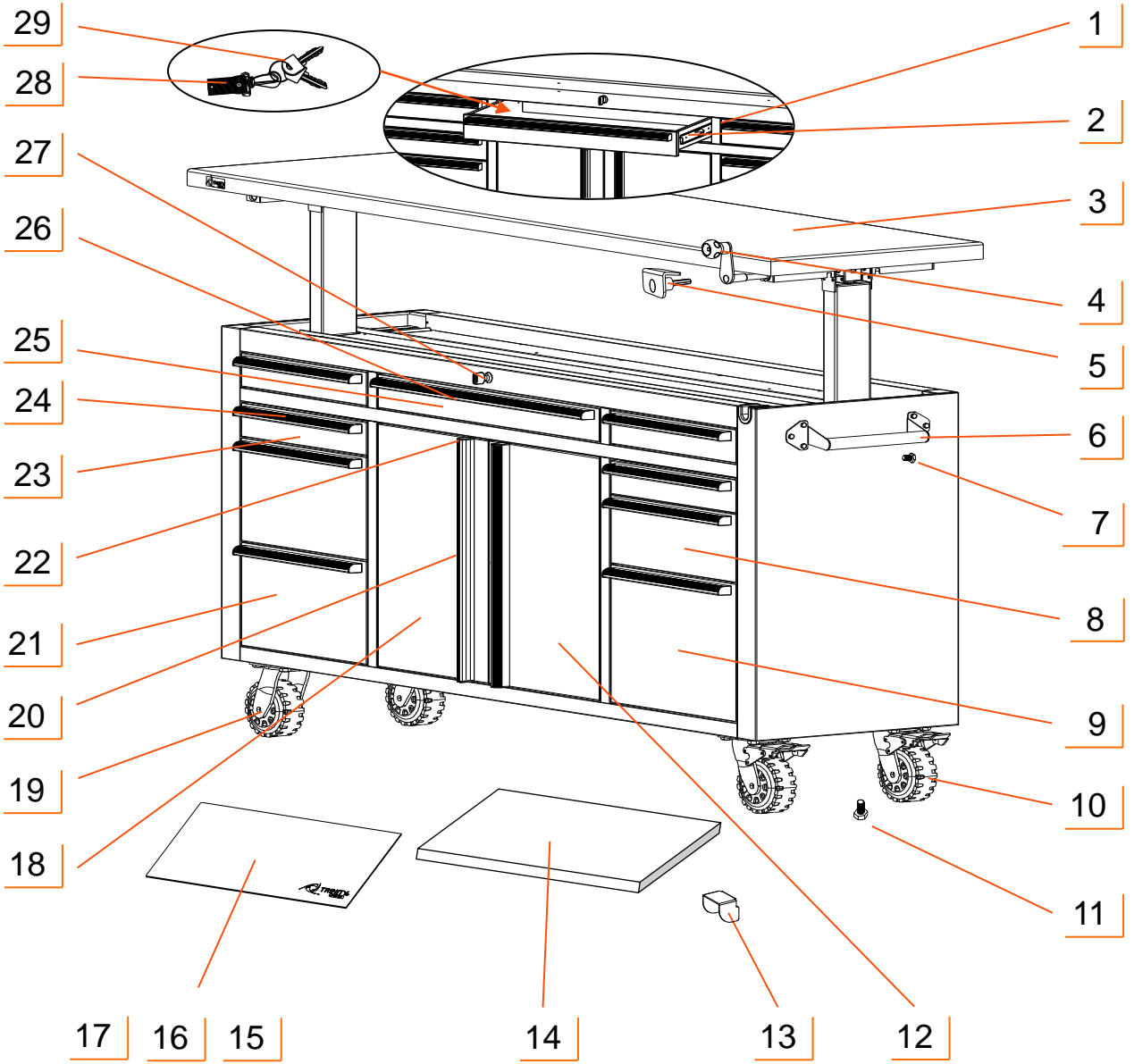

WARNINGS

1. **Read and understand all instructions.** Failure to follow all instructions may result in injury and/or damage.
2. **The warnings, cautions, and instructions discussed in this manual cannot cover all possible conditions or situations that may occur.** The user must always be aware of their environment and ensure that they use the product in a safe and responsible manner.
3. **Do NOT modify the product in any way.** Unauthorized modification may impair the function and/or safety of the product, and may affect the life of the product.
4. **Check for damaged parts.** Before using this product, carefully check that all parts are in good condition, and that the product will operate properly and perform its intended function. Check for damaged parts and any other conditions that may affect the operation of this product. Replace damaged or worn parts, and never use this product with a damaged part.
5. **Do NOT overload the product.** Below capacity is based on evenly distributed weight.

Weight capacity per drawer w/ 1 pair of slides	45.4 kg / 100 lb
Weight capacity per drawer w/ 2 pairs of slides	90.7 kg / 200 lb
Weight capacity of wood top when raised	136.1 kg / 300 lb
Total weight capacity of workbench when wood top lowered	997.9 kg / 2200 lb

6. **Lock the casters when leaving workbench in stationary position.**
7. **Lock the drawers and cabinet before moving the workbench.**
8. **Remove all items from wood top and lower the wood top before moving the workbench.** Items may fall causing injury.
9. **Remove all items from wood top before adjusting wood top height.** Items may fall causing injury. Always install wood top stopper before utilizing raised wood top.
10. **Always move workbench with two people.** Roll slowly and constantly check surroundings to ensure enough clearance. Heavy weight workbench can be hard to stop if moving too fast, causing serious injury or damage.
11. **Do NOT open more than one drawer at a time.** Tipping can occur.
12. **Do NOT step or lean on open drawers.** Tipping can occur.
13. **Do NOT lift workbench by wood top.** Wood top may separate causing injury.
14. **Do NOT hang on the wood top.** Tipping can occur

WARNINGS

15. **Be careful of areas under the wood top when it is being lowered.** Lower slowly and stop immediately if sensing resistance. Crushing of items or body parts can occur.
16. **Do NOT store items underneath the wood top.** Crushing of items can occur.
17. **Do NOT let children play near the workbench.**
18. **Load the workbench starting with the bottom drawers to prevent workbench from tipping.**
19. **Make sure all drawers and cabinet are closed tightly before locking or unlocking.**

CARE AND MAINTENANCE

- Avoid harsh, abrasive cleaners, and other corrosive chemicals.
- Do not use scouring pad for cleaning.
- Keep dry and avoid damp environments.
- Use a quality stainless steel cleaner and follow instructions that come with the cleaner. Wipe ALONG the grain (NOT against).
- Wood top can be cleaned with damp cloth and wiped dry immediately with dry cloth. If needed, solvent-based wood furniture cleaner can be used.
- Clean up any spills immediately to prevent stains from forming on the wood top.

PRODUCT REGISTRATION

Thank you for purchasing a TRINITY PRO 72in Stainless Steel Rolling Workbench w/Adjustable Top. In order to register your product and receive streamlined customer service, please fill out the following Product Registration Form and (1) fax the form to 310.347.4134 (2) complete the Product Registration Form online at www.trinityii.com or (3) scan and email the form to customerservice@trinityii.com. Include a copy of your original receipt with your submission.

First Name: _____ Last Name: _____

Address: _____

City: _____ State: _____ Zip Code: _____

Email Address: _____ Phone: _____

Product Model #: _____ TLSF-7211 _____ Purchase Date: ____ / ____ / ____

Location of Purchase: _____

Please rate the importance of each feature (1=least important; 10=most important)

Quality ____ Price ____ Size/Capacity ____ Appearance ____ Other ____

How did you hear about our product?

- Magazine Ad Catalog Salesperson Word of Mouth
 Internet Store Display Other

Marital Status: Single Married

Household Income: Below \$50,000 \$50,000-\$150,000 \$150,000+

Education: High School College Graduate School

Primary Residence: Own Rent

Comments/Suggestions:



1 YEAR LIMITED WARRANTY

TRINITY PRO 72" Stainless Steel Rolling Workbench w/Adjustable Top Model # TLSF-7211

Trinity International Industries ("Trinity") warrants to the original consumer purchaser ("Purchaser") of the TRINITY PRO 72in Stainless Steel Rolling Workbench w/Adjustable Top ("Product") that each Product shall be free from defects in workmanship and materials for a period of 1 year from the date of original purchase. Trinity's obligation under this warranty shall be limited to repair or replacement of, or adequate compensation for the Product which shall not be greater than the amount of the purchase price of the Product, at the option of Trinity, during the warranty period. All replaced parts and Products become the property of Trinity and must be returned to Trinity.

This warranty excludes normal wear and tear of the Product and its parts or components, and damage arising from any of the following: negligent use or misuse of the Product, use contrary to this User's Manual, or alteration by any one other than Trinity. The warranty period of 1 year shall not be extended or renewed by the repair or replacement of, or compensation for, the Product. Any warranty implied by applicable law is limited in duration to one year from the date of purchase and is subject to the same conditions and limitations as is provided for our express warranty.

Except as set forth herein, and to the extent of applicable there are no warranties on this Product either express or implied, and Trinity disclaims all warranties including, but not limited to, any implied warranties of merchantability, infringement or fitness for a particular purpose. No warranty or guarantee given by any person, firm, or corporation with respect to this product shall be binding on Trinity.

If your Product is defective or otherwise requires service or parts, please call TRINITY Customer Service toll-free at (800) 985-5506, between 5:00 a.m. and 5:00 p.m., PST. Please tell us which model you purchased, the date of the purchase, and the problem with your Product. A copy of your original purchase receipt must accompany your service request.

LIMITATION OF REMEDIES AND LIABILITY

Trinity (and its employees, officers, members, managers, affiliates and assigns) shall not be liable for any incidental, consequential, special, indirect, remote, special or punitive damages for breach of any warranty, express or implied, including, but not limited to, lost profits, lost savings, loss of anticipated benefits and attorneys' fees, which arise out of the purchase, use or inability to use the Product, whether arising out of contract, negligence, strict tort, product liability, or any other legal theory on which a claim is based. As noted above, to the extent damages are allowed by our express warranty or by applicable law, those damages may not exceed the purchase price paid for the Product. Without limiting the foregoing Purchaser assumes all risk and liability for loss, damage or injury to Purchaser and Purchaser's property and to others and their property arising out of the use, misuse, or inability to use this Product. This limited warranty shall not extend to anyone other than the original purchaser of this product, is nontransferable and states your exclusive remedy.

Some states do not allow the exclusion or limitation of incidental, consequential, special, or punitive damages, so the above limitation or exclusion may not apply to you. The above warranty gives you specific legal rights, and you may have other rights which vary from state to state.

CONTACT US

**QUESTIONS? NEED PARTS?
WE ARE HERE TO HELP!**

Please feel free to contact us. There are no questions too small, or any problems too big. We're committed to providing our customers with the highest level of service.

TRINITY Customer Service

TEL: 800.985.5506

FAX: 310.347.4134

EMAIL: customerservice@trinityii.com

**Monday through Friday
5:00 AM – 5:00 PM (PST)**

www.trinityii.com