

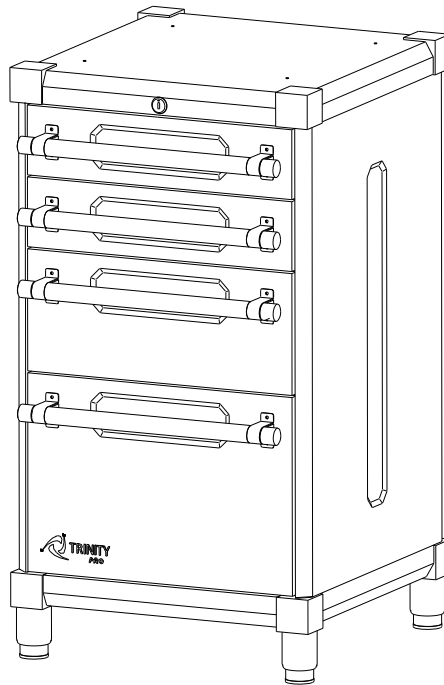

# OWNER'S MANUAL



## TRINITY PRO 18.5" GARAGE BASE CABINET W/DRAWERS Model # TSNPBK-0607



**Important / Important / Importante**

FOR QUICK & EASY 3D ASSEMBLY INSTRUCTIONS

POUR DES DIRECTIVES D'ASSEMBLAGE 3D RAPIDES ET FACILES

PARA INSTRUCCIONES DE ENSAMBLAJE RÁPIDAS Y SENCILLAS EN 3D

# **BILT.**<sup>®</sup>

Intelligent Instructions  
Directives intelligentes  
Instrucciones Inteligentes



DOWNLOAD THE FREE APP | TÉLÉCHARGER L'APPLICATION GRATUITE | DESCARGUE LA APLICACIÓN GRATUITA

# PARTS LIST

Your TRINITY PRO 18.5" Garage Base Cabinet w/Drawers should include the following parts. Please inspect box contents to ensure you have received all components.

If you are missing any parts, need assistance with assembly or have questions, please contact TRINITY Customer Service: 800.985.5506 or [customerservice@trinityii.com](mailto:customerservice@trinityii.com). Parts can also be requested online via "Contact Us" section at [www.trinityii.com](http://www.trinityii.com).

No tools required for assembly.

A

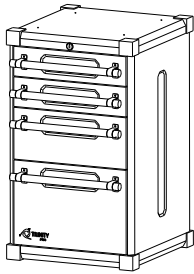

**CABINET BODY (1)**

B

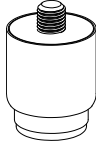

**FEET LEVELER (4)**

C

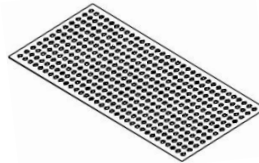

**DRAWER LINER (4)**

D

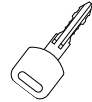

**KEY (2)**

E



**WOOD SCREW (4)**  
Option: only use for  
mounting wood top

## LOCATION OF PARTS:

- 1) KEYS (D) are hooked to key leash mounted inside Top Drawer.
- 2) FEET LEVELERS (B) and WOOD SCREW (E) are boxed inside Second Drawer.
- 3) LINERS (C) are packed inside Second Drawer.

# ASSEMBLY INSTRUCTIONS

## STEP 1

**Location of parts:** KEYS (D) are hooked to key leash mounted inside Top Drawer. FEET LEVELERS (B) and DRAWER LINERS (C) are packed inside Second Drawer.

Lay CABINET BODY (A) gently on its back. Two people are needed, do NOT attempt this alone.

Screw each FEET LEVELER (B) fully into each pre-installed nut on four corners of cabinet bottom.

Stand cabinet right side up.  
Move it to desired location. Adjust each FEET LEVELER (B) as needed to ensure your cabinet is level and stable.

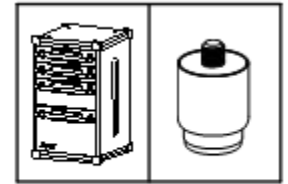

A (1)

B (4)

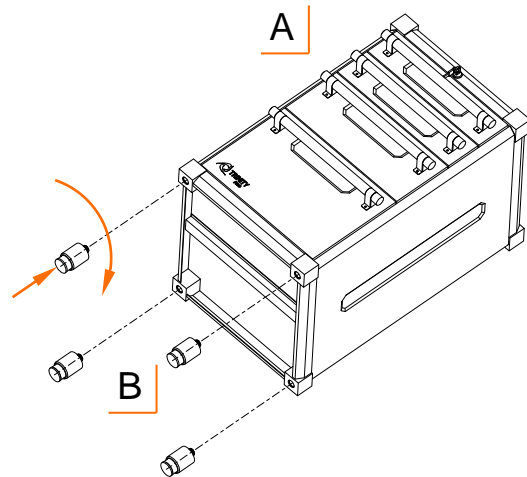

A

B

## STEP 2

Simply place LINERS (C) in each drawer.

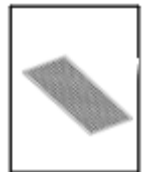

C (4)

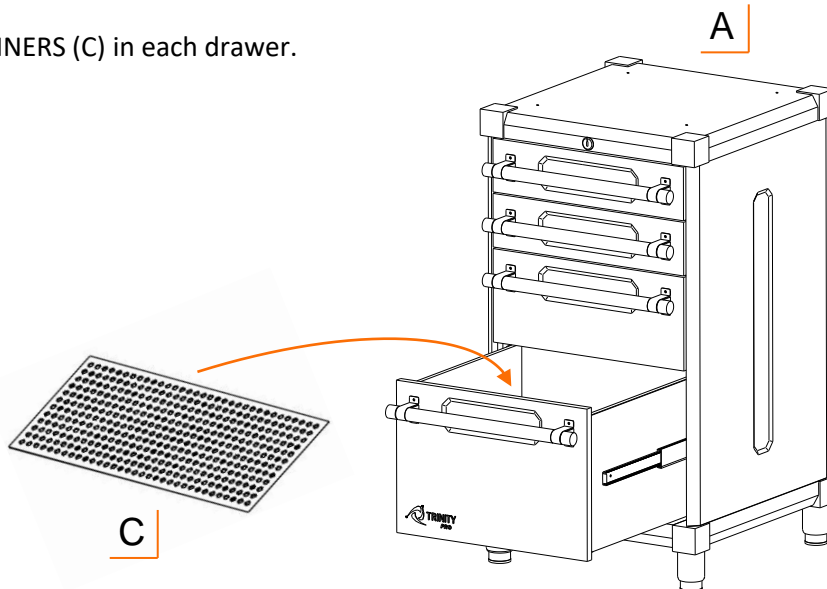

A

C

# USAGE INSTRUCTIONS

## DRAWER REMOVAL

Pull drawer out so that it is almost fully extended. On RIGHT side, push black release lever DOWN. On LEFT side, pull black release lever UP. While holding levers as instructed, pull drawer forward until released from slides attached to Cabinet (“Cabinet Slides”).

**Note:** Slides attached to drawer (“Drawer Slides”) are an integral part of drawer and must be removed along with drawer itself.

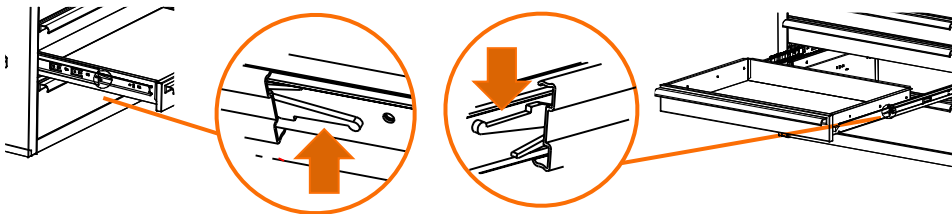

## DRAWER REPLACEMENT

To replace drawer, pull slides out completely. Insert brackets on each side of Drawer Slides into corresponding slots on Cabinet Slides, making sure they are properly positioned. Once brackets are inserted into slots, completely close drawer to set all slides in their proper positions.

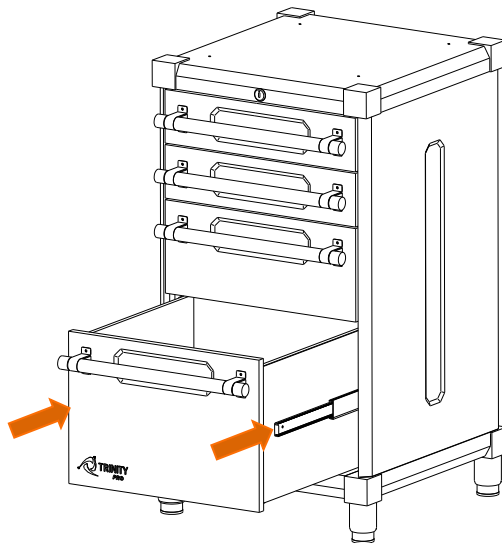

# SERVICE PARTS LIST – TSNPBK-0607

TRINITY Customer Service provides the following replacement parts:

Part Number	Description	Part Number	Description
1) PBK-18-029-1831	Cabinet Body	8) XBK-22-008-1616	Drawer Liner
2) PBK-07-016-1704	Small Drawer	9) PBK-07-016-1711	Large Drawer
3) XBS-05-030-1575	Drawer Handle	10) XBS-02-029-0002	Handle Bracket
4) PBK-07-016-1707	Medium Drawer	11) XBK-02-028-0002	Plastic Spacer
5) ZSV-12-017-1375	Slide (cabinet side)	12) CSV-11-005-0XXX	Lock
6) ZSV-12-016-1375	Slide (drawer side)	13) XBK-10-003-0XXX	Key
7) XBS-98-012-1662	Feet Leveler	14) XBK-02-054-0001	Key Leash

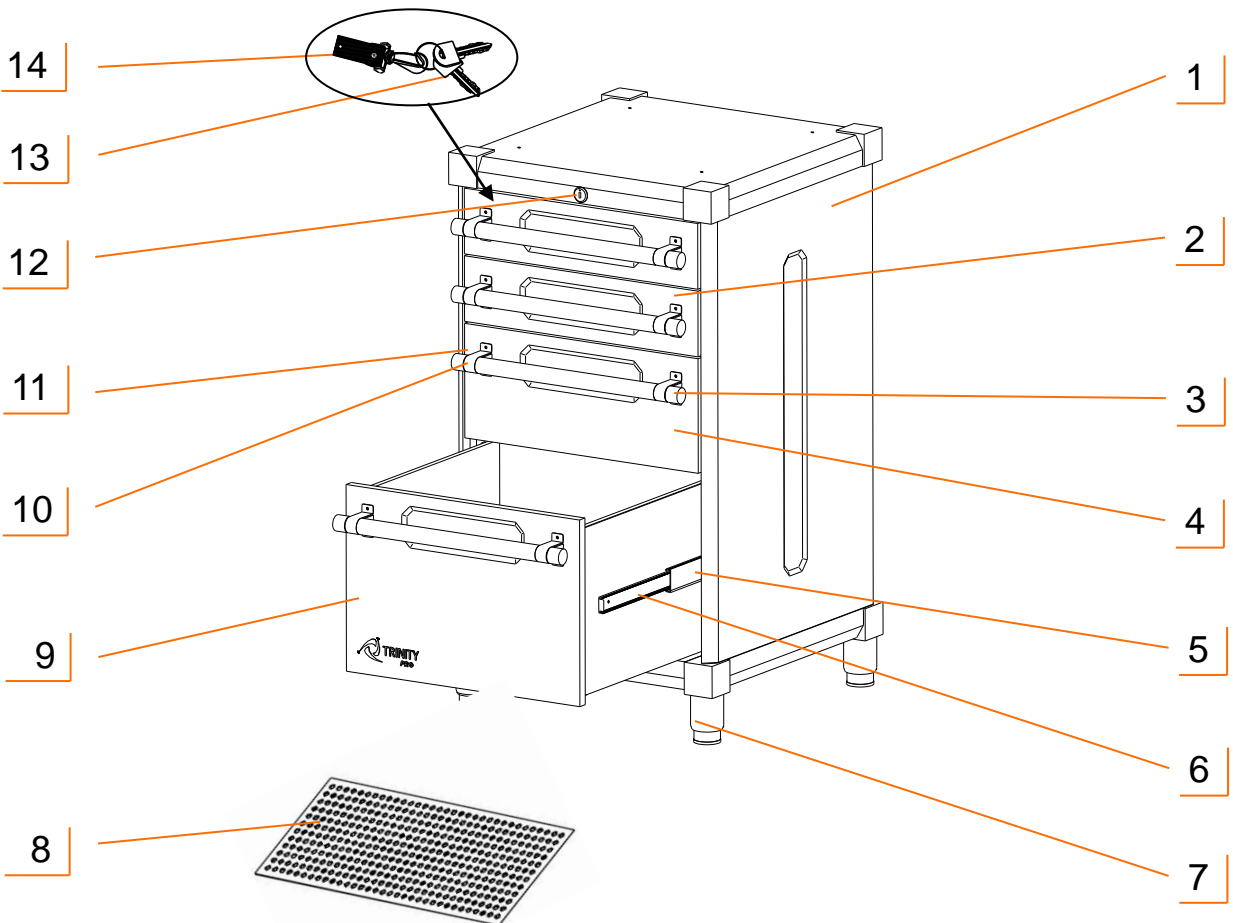

---

## WARNINGS

1. **Read and understand all instructions.** Failure to follow all instructions may result in injury and/or damage.
2. **The warnings, cautions, and instructions discussed in this manual cannot cover all possible conditions or situations that may occur.** The user must always be aware of their environment and ensure that they use the product in a safe and responsible manner.
3. **Do NOT modify the product in any way.** Unauthorized modification may impair the function and/or safety of the product, and may affect the life of the product.
4. **Check for damaged parts.** Before using this product, carefully check that all parts are in good condition, and that the product will operate properly and perform its intended function. Check for damaged parts and any other conditions that may affect the operation of this product. Replace damaged or worn parts, and never use this product with a damaged part.
5. **Do NOT overload the product.** Below capacity is based on evenly distributed weight.

Weight capacity per drawer (evenly distributed)	100 lb
Total weight capacity of cabinet (evenly distributed)	400 lb

6. **Lock the drawers before moving the cabinet.**
7. **Do NOT open more than one drawer at a time.** Tipping can occur.
8. **Do NOT step or lean on open drawers.** Tipping can occur.
9. **Load the cabinet starting with the bottom drawers to prevent cabinet from tipping.**
10. **Make sure all drawers are closed tightly before locking or unlocking.**

---

## CARE AND MAINTENANCE

- Avoid harsh, abrasive cleaners, and other corrosive chemicals.
- Do not use scouring pad for cleaning.
- This item is not certified for outdoor use.

# PRODUCT REGISTRATION

Thank you for purchasing a TRINITY PRO 18.5" Garage Base Cabinet w/Drawers. In order to register your product and receive streamlined customer service, please fill out the following Product Registration Form and (1) fax the form to 310.347.4134 (2) complete the Product Registration Form online at [www.trinityii.com](http://www.trinityii.com) or (3) scan and email the form to [customerservice@trinityii.com](mailto:customerservice@trinityii.com). Include a copy of your original receipt with your submission.

First Name: \_\_\_\_\_ Last Name: \_\_\_\_\_

Address: \_\_\_\_\_

City: \_\_\_\_\_ State: \_\_\_\_\_ Zip Code: \_\_\_\_\_

Email Address: \_\_\_\_\_ Phone: \_\_\_\_\_

Product Model #: TSNPBK-0607 Purchase Date: \_\_\_\_ / \_\_\_\_ / \_\_\_\_

Location of Purchase: \_\_\_\_\_

Please rate the importance of each feature (1=least important; 10=most important)

Quality \_\_\_\_ Price \_\_\_\_ Size/Capacity \_\_\_\_ Appearance \_\_\_\_ Other \_\_\_\_

How did you hear about our product?

- Magazine Ad     Catalog     Salesperson     Word of Mouth  
 Internet     Store Display     Other

Marital Status:                       Single                       Married

Household Income:                 Below \$50,000     \$50,000-\$150,000     \$150,000+

Education:                           High School             College             Graduate School

Primary Residence:                 Own                       Rent

Comments/Suggestions:

# 1 YEAR LIMITED WARRANTY

## TRINITY PRO 18.5" Garage Base Cabinet w/Drawers Model # TSNPBK-0607

Trinity International Industries ("Trinity") warrants to the original consumer purchaser ("Purchaser") of the TRINITY PRO 18.5" Garage Base Cabinet w/Drawers ("Product") that each Product shall be free from defects in workmanship and materials for a period of 1 year from the date of original purchase. Trinity's obligation under this warranty shall be limited to repair or replacement of, or adequate compensation for the Product which shall not be greater than the amount of the purchase price of the Product, at the option of Trinity, during the warranty period. All replaced parts and Products become the property of Trinity and must be returned to Trinity.

This warranty excludes normal wear and tear of the Product and its parts or components, and damage arising from any of the following: negligent use or misuse of the Product, use contrary to this User's Manual, or alteration by any one other than Trinity. The warranty period of 1 year shall not be extended or renewed by the repair or replacement of, or compensation for, the Product. Any warranty implied by applicable law is limited in duration to one year from the date of purchase and is subject to the same conditions and limitations as is provided for our express warranty.

Except as set forth herein, and to the extent of applicable there are no warranties on this Product either express or implied, and Trinity disclaims all warranties including, but not limited to, any implied warranties of merchantability, infringement or fitness for a particular purpose. No warranty or guarantee given by any person, firm, or corporation with respect to this product shall be binding on Trinity.

If your Product is defective or otherwise requires service or parts, please call TRINITY Customer Service toll-free at (800) 985-5506, between 5:00 a.m. and 5:00 p.m., PST. Please tell us which model you purchased, the date of the purchase, and the problem with your Product. A copy of your original purchase receipt must accompany your service request.

### LIMITATION OF REMEDIES AND LIABILITY

Trinity (and its employees, officers, members, managers, affiliates and assigns) shall not be liable for any incidental, consequential, special, indirect, remote, special or punitive damages for breach of any warranty, express or implied, including, but not limited to, lost profits, lost savings, loss of anticipated benefits and attorneys' fees, which arise out of the purchase, use or inability to use the Product, whether arising out of contract, negligence, strict tort, product liability, or any other legal theory on which a claim is based. As noted above, to the extent damages are allowed by our express warranty or by applicable law, those damages may not exceed the purchase price paid for the Product. Without limiting the foregoing Purchaser assumes all risk and liability for loss, damage or injury to Purchaser and Purchaser's property and to others and their property arising out of the use, misuse, or inability to use this Product. This limited warranty shall not extend to anyone other than the original purchaser of this product, is nontransferable and states your exclusive remedy.

Some states do not allow the exclusion or limitation of incidental, consequential, special, or punitive damages, so the above limitation or exclusion may not apply to you. The above warranty gives you specific legal rights, and you may have other rights which vary from state to state.



---

## CONTACT US

**QUESTIONS? NEED PARTS?  
WE ARE HERE TO HELP!**

**Please feel free to contact us. There are no questions too small, or any problems too big. We're committed to providing our customers with the highest level of service.**

### **TRINITY Customer Service**

**TEL: 800.985.5506**

**FAX: 310.347.4134**

**EMAIL: [customerservice@trinityii.com](mailto:customerservice@trinityii.com)**

**Monday through Friday  
5:00 AM – 5:00 PM (PST)**

**[www.trinityii.com](http://www.trinityii.com)**



## OWNER'S MANUAL

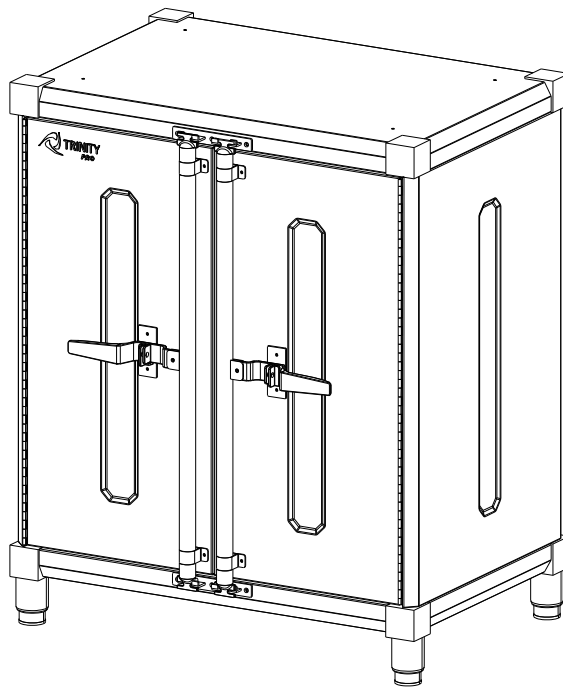

### TRINITY PRO 28" BASE CABINET W/ DOORS Model # TSNPBK-0608



Important / Important / Importante

FOR QUICK & EASY 3D ASSEMBLY INSTRUCTIONS

POUR DES DIRECTIVES D'ASSEMBLAGE 3D RAPIDES ET FACILES

PARA INSTRUCCIONES DE ENSAMBLAJE RÁPIDAS Y SENCILLAS EN 3D

# BILT.®

Intelligent Instructions  
Directives intelligentes  
Instrucciones Inteligentes



DOWNLOAD THE FREE APP | TÉLÉCHARGER L'APPLICATION GRATUITE | DESCARGUE LA APLICACIÓN GRATUITA

# PARTS LIST

Your TRINITY PRO 28" Base Cabinet w/Doors should include the following parts. Please inspect box contents to ensure you have received all components.

If you are missing any parts, need assistance with assembly or have questions, please contact TRINITY Customer Service: 800.985.5506 or [customerservice@trinityii.com](mailto:customerservice@trinityii.com). Parts can also be requested online via "Contact Us" section at [www.trinityii.com](http://www.trinityii.com).

You will NOT need additional tools for assembly.

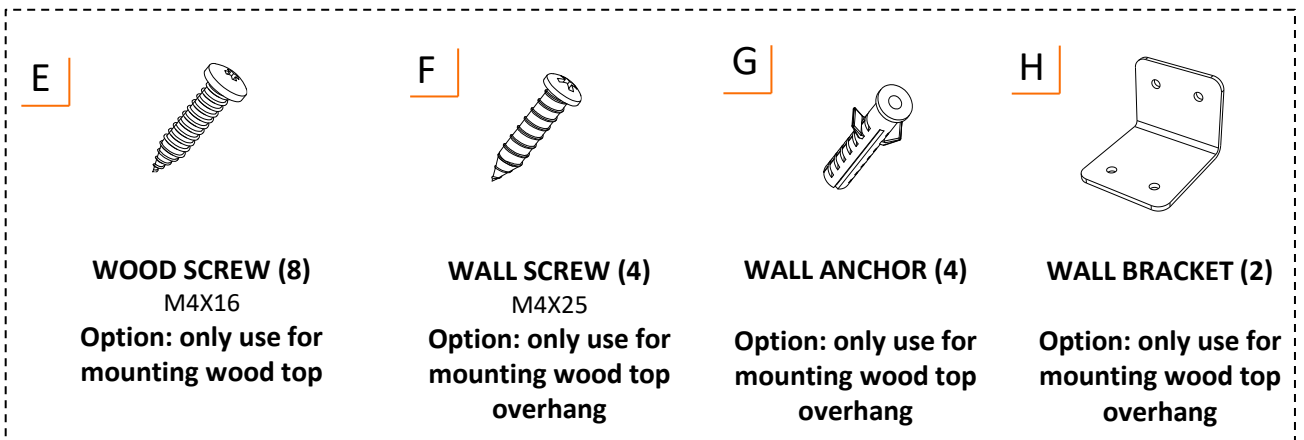
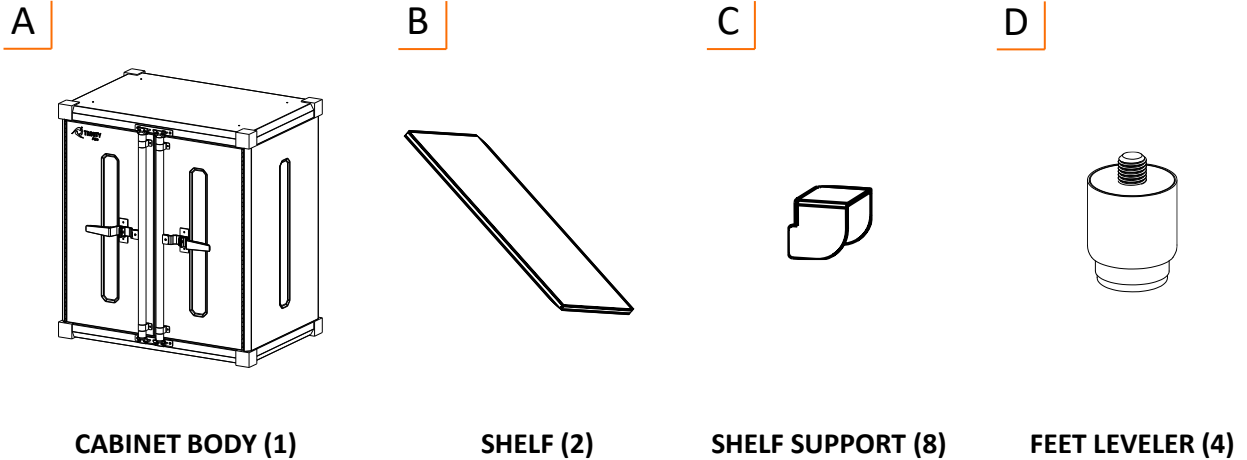

# ASSEMBLY INSTRUCTIONS

## STEP 1

Lay CABINET BODY (A) gently on its back. Two people are needed, Do NOT attempt this alone.

Screw FEET LEVELER (D) fully into each pre-installed nut on four corners of cabinet bottom.

Stand cabinet right side up. Move it to desired location. Adjust FEET LEVELER (D) as needed to ensure your cabinet is level and stable.

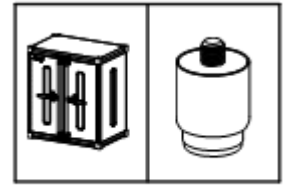
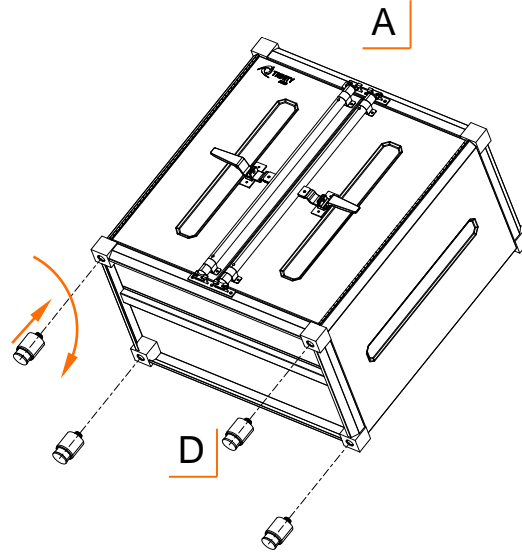

A (1)

D (4)

## STEP 2

Attach SHELF SUPPORT (C) by hooking it over position tab at desired height. Make sure all four SHELF SUPPORTS (C) are at the same level.

Tilt SHELF (B) diagonally to move it inside cabinet. Place SHELF (B) on top of all four SHELF SUPPORTS (C).

Repeat above to install other shelf.

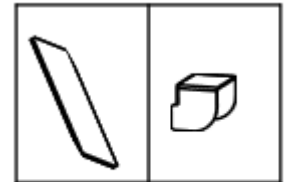

B (2)

C (8)

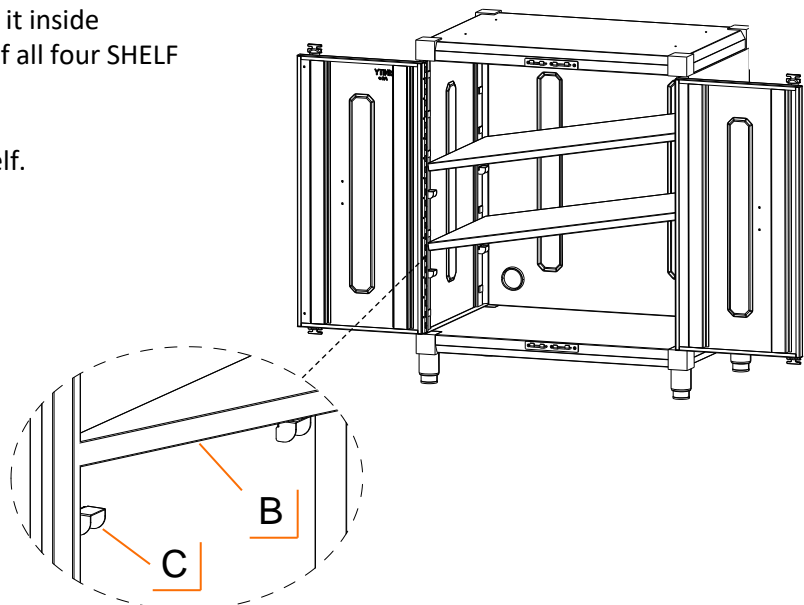

# USAGE INSTRUCTIONS

## OPEN AND CLOSE DOOR

Lift up door handle to release it from slot on handle base plate, rotate it forward and pull it to open door.

Close door by making sure ends of door bar is pushed against the stopper plate both on top and bottom. Rotate the door handle against door and slide into the slot on door handle base plate to keep door closed.

**Note:** To lock the door you need to buy a padlock with shackle diameter no larger than 9/32" (7mm). Put the shackle through the holes on door handle and handle base plate to lock the door.

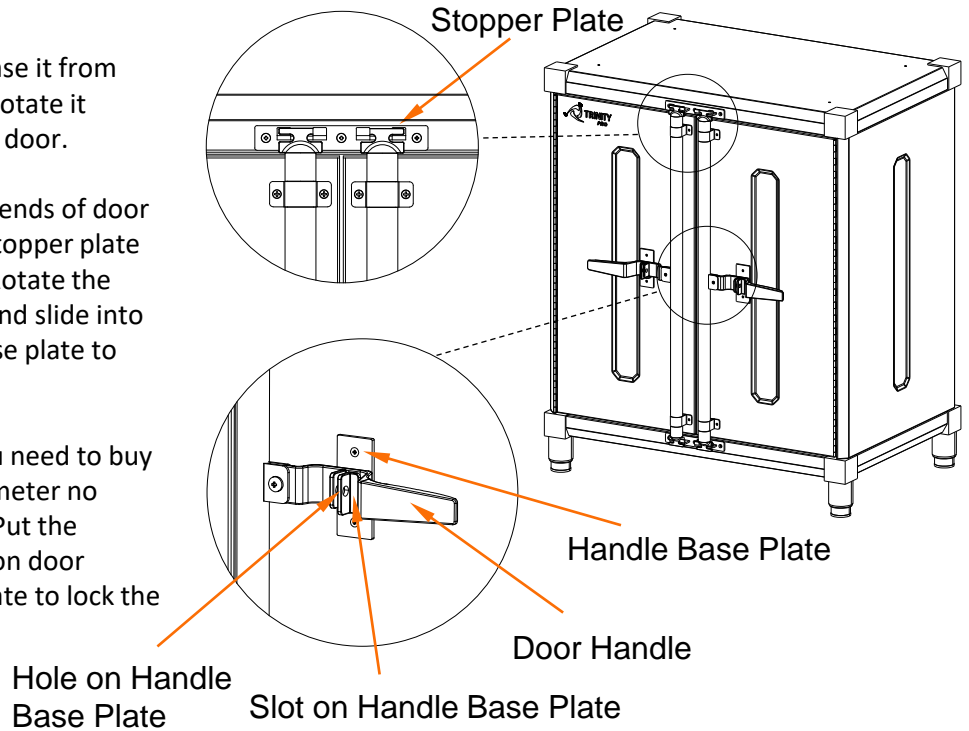

## SHELF ADJUSTMENT

Ensure all items have been removed from shelf.

To adjust shelf height position, take shelf out of cabinet and re-attach shelf supports to position tabs at desired height.

Tilt shelf diagonally to move it inside cabinet. Place shelf on top of all shelf supports.

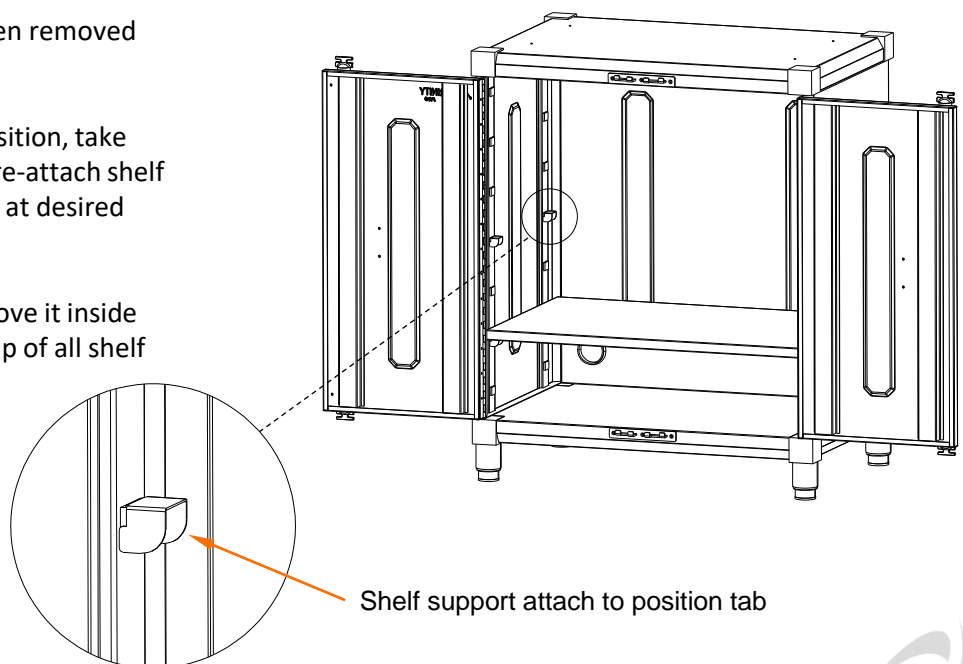

# SERVICE PARTS LIST – TSNPBK-0608

TRINITY Customer Service provides the following replacement parts:

Part Number	Description	Part Number	Description
1) PBK-18-020-2819	Cabinet Body	9) XSV-02-017-0001	Shelf Support
2) XSV-09-009-0003	Door Hinge	10) XSV-01-010-0616	Handle Screw
3) XBS-02-030-0002	Right Handle Base Plate	11) XBS-02-030-0001	Left Handle Base Plate
4) XBS-05-025-0720	Handle	12) XSV-01-010-0408	Lock Bar Bracket Screw
5) XBS-05-026-2875	Lock Bar	13) XBK-02-028-0001	Plastic Spacer
6) XBS-02-029-0001	Lock Bar Bracket	14) XBS-02-027-0001	Lock Bar Stopper
7) XBS-98-012-1662	Feet Leveler	15) XSV-01-027-0408	Stopper Screw
8) PBK-03-073-1627	Shelf		

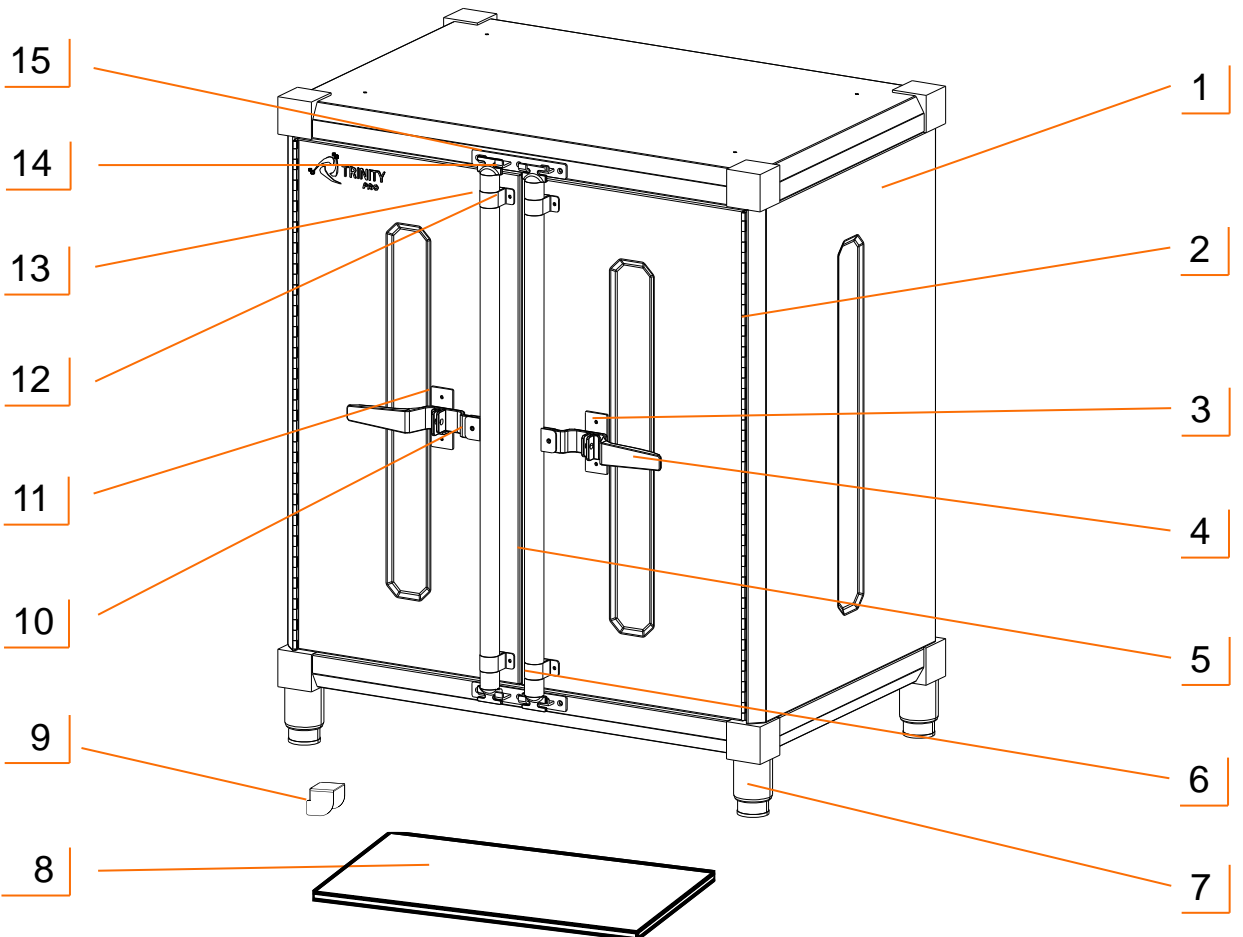

---

## WARNINGS

1. **Read and understand all instructions.** Failure to follow all instructions may result in injury and/or damage.
2. **The warnings, cautions, and instructions discussed in this manual cannot cover all possible conditions or situations that may occur.** The user must always be aware of their environment and ensure that they use the product in a safe and responsible manner.
3. **Do NOT modify the product in any way.** Unauthorized modification may impair the function and/or safety of the product, and may affect the life of the product.
4. **Check for damaged parts.** Before using this product, carefully check that all parts are in good condition, and that the product will operate properly and perform its intended function. Check for damaged parts and any other conditions that may affect the operation of this product. Replace damaged or worn parts, and never use this product with a damaged part.
5. **Do NOT overload the product.**

Weight capacity per shelf (evenly distributed)	150 lb
Total weight capacity of cabinet (evenly distributed)	600 lb

---

## CARE AND MAINTENANCE

- Avoid harsh, abrasive cleaners, and other corrosive chemicals.
- Do not use scouring pad for cleaning.
- This item is not certified for outdoor use.

# PRODUCT REGISTRATION

Thank you for purchasing a TRINITY PRO 28" Base Cabinet w/Doors. In order to register your product and receive streamlined customer service, please fill out the following Product Registration Form and (1) fax the form to 310.347.4134 (2) complete the Product Registration Form online at [www.trinityii.com](http://www.trinityii.com) or (3) scan and email the form to [customerservice@trinityii.com](mailto:customerservice@trinityii.com). Include a copy of your original receipt with your submission.

First Name: \_\_\_\_\_ Last Name: \_\_\_\_\_

Address: \_\_\_\_\_

City: \_\_\_\_\_ State: \_\_\_\_\_ Zip Code: \_\_\_\_\_

Email Address: \_\_\_\_\_ Phone: \_\_\_\_\_

Product Model #: TSNPBK-0608 Purchase Date: \_\_\_\_ / \_\_\_\_ / \_\_\_\_

Location of Purchase: \_\_\_\_\_

Please rate the importance of each feature (1=least important; 10=most important)

Quality \_\_\_\_ Price \_\_\_\_ Size/Capacity \_\_\_\_ Appearance \_\_\_\_ Other \_\_\_\_

How did you hear about our product?

- Magazine Ad     Catalog     Salesperson     Word of Mouth  
 Internet     Store Display     Other

Marital Status:                       Single                       Married

Household Income:                 Below \$50,000     \$50,000-\$150,000     \$150,000+

Education:                           High School             College             Graduate School

Primary Residence:                 Own                       Rent

Comments/Suggestions:



# 1 YEAR LIMITED WARRANTY

## TRINITY PRO 28" Base Cabinet w/Doors Model # TSNPBK-0608

Trinity International Industries ("Trinity") warrants to the original consumer purchaser ("Purchaser") of the TRINITY PRO 28" Base Cabinet w/Doors ("Product") that each Product shall be free from defects in workmanship and materials for a period of 1 year from the date of original purchase. Trinity's obligation under this warranty shall be limited to repair or replacement of, or adequate compensation for the Product which shall not be greater than the amount of the purchase price of the Product, at the option of Trinity, during the warranty period. All replaced parts and Products become the property of Trinity and must be returned to Trinity.

This warranty excludes normal wear and tear of the Product and its parts or components, and damage arising from any of the following: negligent use or misuse of the Product, use contrary to this User's Manual, or alteration by any one other than Trinity. The warranty period of 1 year shall not be extended or renewed by the repair or replacement of, or compensation for, the Product. Any warranty implied by applicable law is limited in duration to one year from the date of purchase and is subject to the same conditions and limitations as is provided for our express warranty.

Except as set forth herein, and to the extent of applicable there are no warranties on this Product either express or implied, and Trinity disclaims all warranties including, but not limited to, any implied warranties of merchantability, infringement or fitness for a particular purpose. No warranty or guarantee given by any person, firm, or corporation with respect to this product shall be binding on Trinity.

If your Product is defective or otherwise requires service or parts, please call TRINITY Customer Service toll-free at (800) 985-5506, between 5:00 a.m. and 5:00 p.m., PST. Please tell us which model you purchased, the date of the purchase, and the problem with your Product. A copy of your original purchase receipt must accompany your service request.

### LIMITATION OF REMEDIES AND LIABILITY

Trinity (and its employees, officers, members, managers, affiliates and assigns) shall not be liable for any incidental, consequential, special, indirect, remote, special or punitive damages for breach of any warranty, express or implied, including, but not limited to, lost profits, lost savings, loss of anticipated benefits and attorneys' fees, which arise out of the purchase, use or inability to use the Product, whether arising out of contract, negligence, strict tort, product liability, or any other legal theory on which a claim is based. As noted above, to the extent damages are allowed by our express warranty or by applicable law, those damages may not exceed the purchase price paid for the Product. Without limiting the foregoing Purchaser assumes all risk and liability for loss, damage or injury to Purchaser and Purchaser's property and to others and their property arising out of the use, misuse, or inability to use this Product. This limited warranty shall not extend to anyone other than the original purchaser of this product, is nontransferable and states your exclusive remedy.

Some states do not allow the exclusion or limitation of incidental, consequential, special, or punitive damages, so the above limitation or exclusion may not apply to you. The above warranty gives you specific legal rights, and you may have other rights which vary from state to state.

---

## CONTACT US

**QUESTIONS? NEED PARTS?  
WE ARE HERE TO HELP!**

**Please feel free to contact us. There are no questions too small, or any problems too big. We're committed to providing our customers with the highest level of service.**

### **TRINITY Customer Service**

**TEL: 800.985.5506**

**FAX: 310.347.4134**

**EMAIL: [customerservice@trinityii.com](mailto:customerservice@trinityii.com)**

**Monday through Friday  
5:00 AM – 5:00 PM (PST)**

**[www.trinityii.com](http://www.trinityii.com)**



## OWNER'S MANUAL

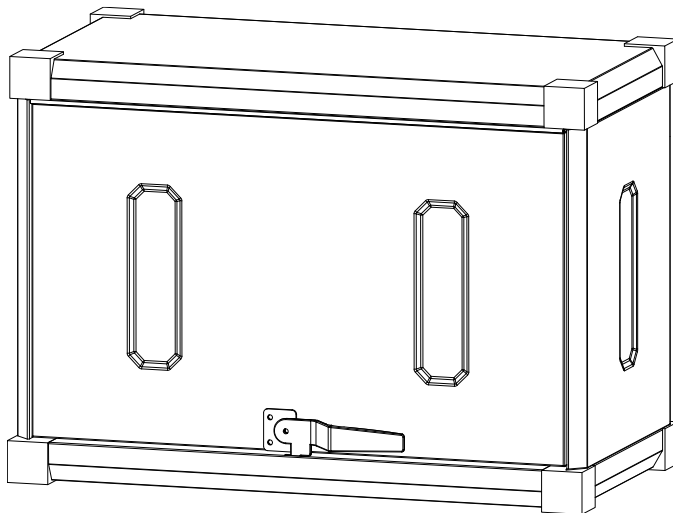

### TRINITY PRO 28" WALL CABINET Model # TSNPBK-0609



**Important / Important / Importante**

FOR QUICK & EASY 3D ASSEMBLY INSTRUCTIONS

POUR DES DIRECTIVES D'ASSEMBLAGE 3D RAPIDES ET FACILES

PARA INSTRUCCIONES DE ENSAMBLAJE RÁPIDAS Y SENCILLAS EN 3D

**BILT.**<sup>®</sup>

Intelligent Instructions  
Directives intelligentes  
Instrucciones Inteligentes



DOWNLOAD THE FREE APP | TÉLÉCHARGER L'APPLICATION GRATUITE | DESCARGUE LA APLICACIÓN GRATUITA

# PARTS LIST

Your TRINITY PRO 28" Wall Cabinet should include the following parts. Please inspect box contents to ensure you have received all components.

If you are missing any parts, need assistance with assembly or have questions, please contact TRINITY Customer Service: 800.985.5506 or [customerservice@trinityii.com](mailto:customerservice@trinityii.com). Parts can also be requested online via "Contact Us" section at [www.trinityii.com](http://www.trinityii.com).

You will need a Phillips screwdriver for assembly which is not provided.

**A**

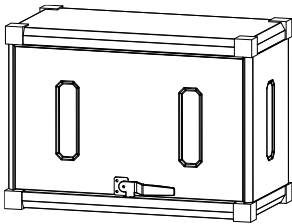

**CABINET BODY (1)**

**B**

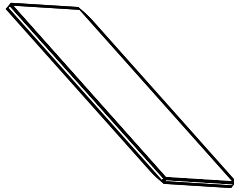

**SHELF (1)**

**C**



**SHELF SUPPORT (4)**

**D**

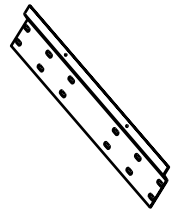

**WALL BRACKET (1)**

**E**



**SHORT SCREW  
(2) + (1) extra**

**F**



**LONG SCREW (4)**

**G**



**ANCHOR (4)**

# ASSEMBLY INSTRUCTIONS

## STEP 1

Position WALL BRACKET (D) on wall at desired height, making sure it is level.

Mark off mounting location on wall through oval holes on WALL BRACKET (D). If ANCHORS (G) are required, drill holes in marked locations. Insert ANCHOR (G) completely into each drilled hole.

Fasten LONG SCREWS (F) through oval holes on WALL BRACKET (D) into wall or anchors tightly with a Phillips screwdriver.

**Note:** Please consult a local contractor if you are unsure if your wall is able to bear the load of the wall cabinet.

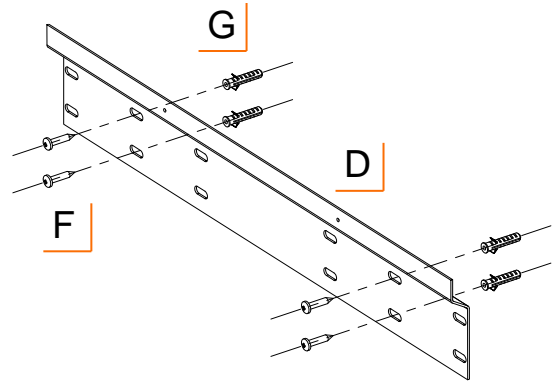
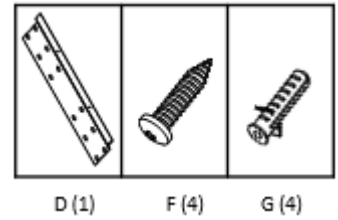

## STEP 2

Lift CABINET BODY (A) and hang it carefully on WALL BRACKET (D) through four hooks on back side of cabinet. Two people are needed, DO NOT attempt this alone.

There are two slots on back side of cabinet. Align these two slots to two small round holes on WALL BRACKET (D). Insert SHORT SCREWS (E) through slots from inside of cabinet and fasten tightly to WALL BRACKET (D) with a Phillips screwdriver.

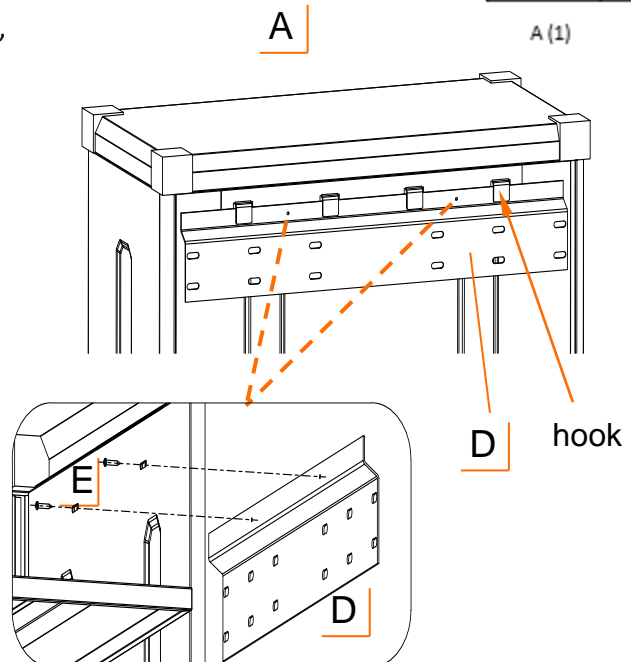
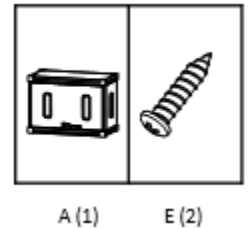

# ASSEMBLY INSTRUCTIONS

## STEP 3

Open cabinet door by lifting up door handle.

Attach SHELF SUPPORT (C) by hooking it over position tab at desired height. Make sure all four SHELF SUPPORTS (C) are at same level.

Tilt SHELF (B) diagonally to move it inside cabinet. Place SHELF (B) on top of all four SHELF SUPPORTS (C).

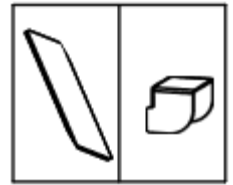

B (1)

C (4)

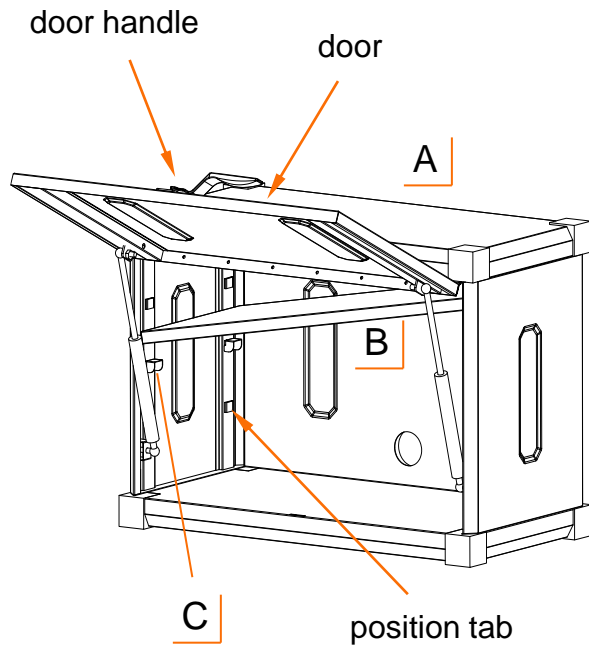

door handle

door

A

B

C

position tab

# USAGE INSTRUCTIONS

## OPEN AND CLOSE DOOR

Open door by lifting up door handle. Close door by pushing down door handle until it fit inside slot on bottom edge of cabinet body. The door will not stay closed if the handle is not in the slot.

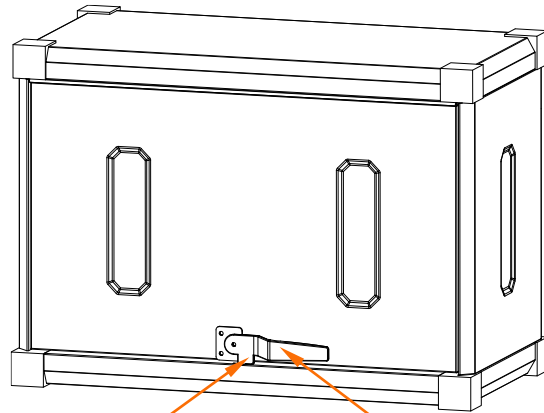

Slot on bottom edge  
of cabinet body

Door Handle

## SHELF ADJUSTMENT

Ensure all items have been removed from shelf.

To adjust shelf height position, take shelf out of cabinet, re-attach shelf supports to position tabs at desired height.

Tilt shelf diagonally to move it inside cabinet. Place shelf on top of all shelf supports.

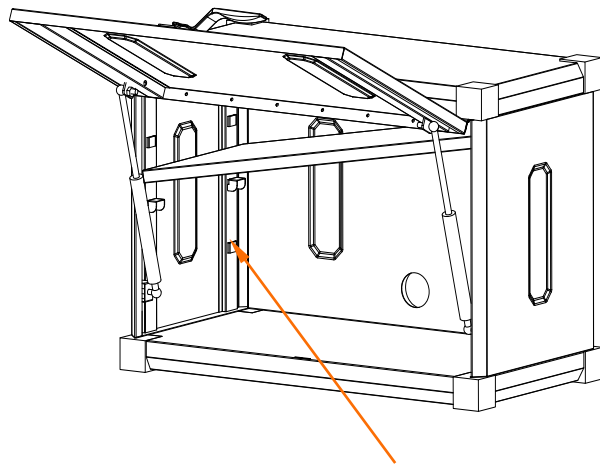

position tab

# SERVICE PARTS LIST – TSNPBK-0609

TRINITY Customer Service provides the following replacement parts:

Part Number	Description	Part Number	Description
1) PBK-18-020-2814	Cabinet Body	7) XSV-02-017-0001	Shelf Support
2) PBK-08-013-2616	Door	8) XSV-01-027-0416	Handle Screw
3) XSV-09-009-0002	Door Hinge	9) XSV-01-027-0408	Handle Base Plate Screw
4) ZBK-09-014-0001	Gas Lift	10) XBS-02-030-0003	Handle Base Plate
5) PBK-03-073-1227	Shelf	11) XBS-05-025-0700	Handle
6) PBK-02-011-0011	Wall Mount Hardware Kit		

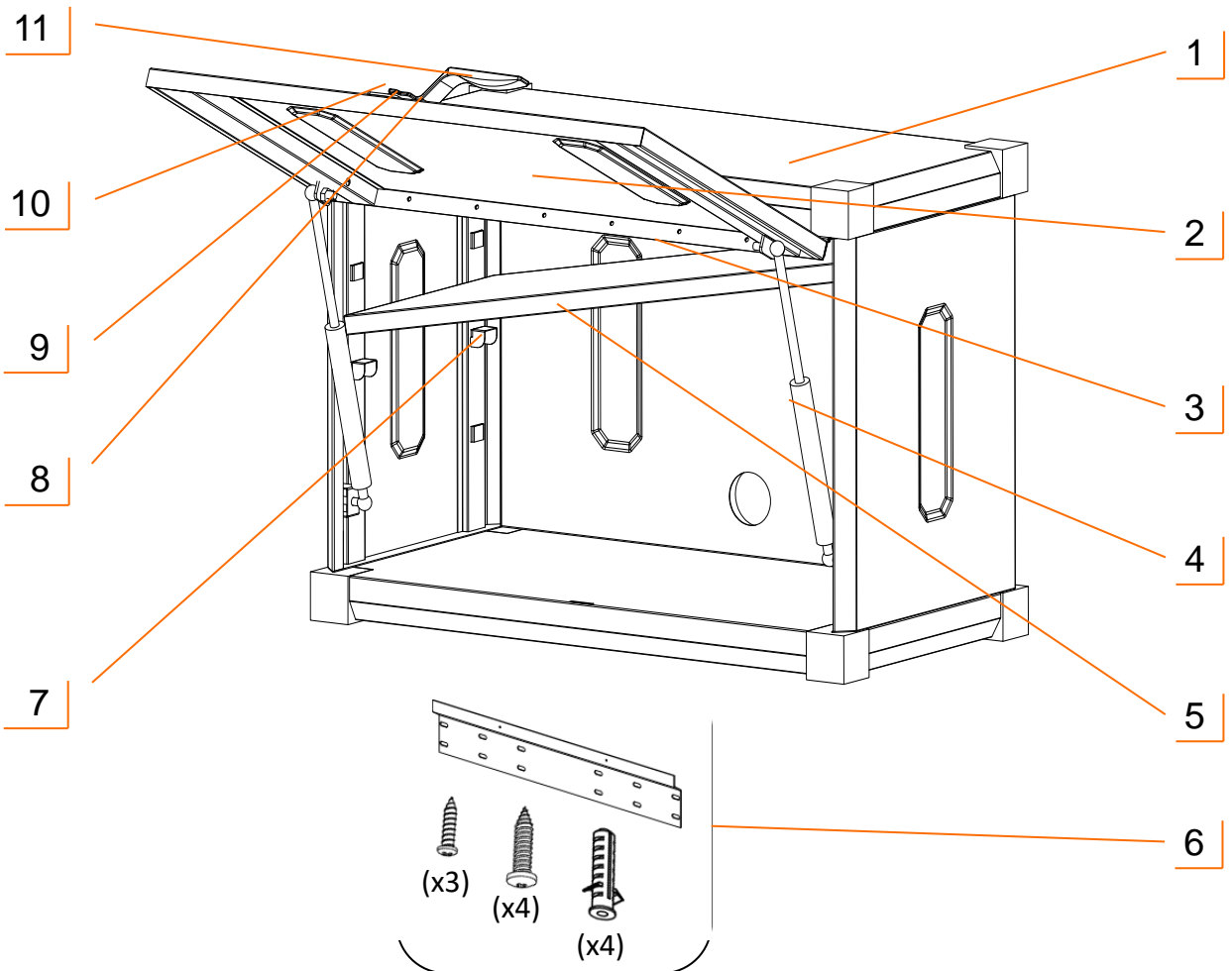



## WARNINGS

1. **Read and understand all instructions.** Failure to follow all instructions may result in injury and/or damage.
2. **The warnings, cautions, and instructions discussed in this manual cannot cover all possible conditions or situations that may occur.** The user must always be aware of their environment and ensure that they use the product in a safe and responsible manner.
3. **Do NOT modify the product in any way.** Unauthorized modification may impair the function and/or safety of the product, and may affect the life of the product. Any modifications will void warranty.
4. **Check for damaged parts.** Before using this product, carefully check that all parts are in good condition, and that the product will operate properly and perform its intended function. Check for damaged parts and any other conditions that may affect the operation of this product. Replace damaged or worn parts, and never use this product with a damaged part.
5. **Do NOT overload the product.**

Weight capacity per shelf (evenly distributed)	100 lb
Total weight capacity of cabinet (evenly distributed)	300 lb

6. **Do NOT hang or use cabinet unless your wall is able to bear the cabinet load.** Consult a local contractor if you are unsure if your wall is able to bear the load of the wall cabinet.
7. **Do NOT use nails to mount the cabinet.**
8. **Do NOT use wall cabinet unless all screws are securely tightened.** Check regularly to ensure screws have not loosened during use of cabinet.
9. **Do NOT hang on the cabinet.**
10. **Do NOT let children play under the cabinet.**
11. **Keep hands and other items away from gas lift when closing the door.** Hands may be pinched or items damaged.

## CARE AND MAINTENANCE

- Avoid harsh, abrasive cleaners, and other corrosive chemicals.
- Do not use scouring pad for cleaning.
- This item is not certified for outdoor use.

# PRODUCT REGISTRATION

Thank you for purchasing a TRINITY PRO 28" Wall Cabinet. In order to register your product and receive streamlined customer service, please fill out the following Product Registration Form and (1) fax the form to 310.347.4134 (2) complete the Product Registration Form online at [www.trinityii.com](http://www.trinityii.com) or (3) scan and email the form to [customerservice@trinityii.com](mailto:customerservice@trinityii.com). Include a copy of your original receipt with your submission.

First Name: \_\_\_\_\_ Last Name: \_\_\_\_\_

Address: \_\_\_\_\_

City: \_\_\_\_\_ State: \_\_\_\_\_ Zip Code: \_\_\_\_\_

Email Address: \_\_\_\_\_ Phone: \_\_\_\_\_

Product Model #: TSNPBK-0609 Purchase Date: \_\_\_\_ / \_\_\_\_ / \_\_\_\_

Location of Purchase: \_\_\_\_\_

Please rate the importance of each feature (1=least important; 10=most important)

Quality \_\_\_\_ Price \_\_\_\_ Size/Capacity \_\_\_\_ Appearance \_\_\_\_ Other \_\_\_\_

How did you hear about our product?

- Magazine Ad     Catalog     Salesperson     Word of Mouth  
 Internet     Store Display     Other

Marital Status:                     Single                     Married

Household Income:             Below \$50,000     \$50,000-\$150,000     \$150,000+

Education:                     High School     College     Graduate School

Primary Residence:             Own                     Rent

Comments/Suggestions:

---

# 1 YEAR LIMITED WARRANTY

## TRINITY PRO 28" Wall Cabinet Model # TSNPBK-0609

Trinity International Industries ("Trinity") warrants to the original consumer purchaser ("Purchaser") of the TRINITY PRO 28" Wall Cabinet ("Product") that each Product shall be free from defects in workmanship and materials for a period of 1 year from the date of original purchase. Trinity's obligation under this warranty shall be limited to repair or replacement of, or adequate compensation for the Product which shall not be greater than the amount of the purchase price of the Product, at the option of Trinity, during the warranty period. All replaced parts and Products become the property of Trinity and must be returned to Trinity.

This warranty excludes normal wear and tear of the Product and its parts or components, and damage arising from any of the following: negligent use or misuse of the Product, use contrary to this User's Manual, or alteration by any one other than Trinity. The warranty period of 1 year shall not be extended or renewed by the repair or replacement of, or compensation for, the Product. Any warranty implied by applicable law is limited in duration to one year from the date of purchase and is subject to the same conditions and limitations as is provided for our express warranty.

Except as set forth herein, and to the extent of applicable there are no warranties on this Product either express or implied, and Trinity disclaims all warranties including, but not limited to, any implied warranties of merchantability, infringement or fitness for a particular purpose. No warranty or guarantee given by any person, firm, or corporation with respect to this product shall be binding on Trinity.

If your Product is defective or otherwise requires service or parts, please call TRINITY Customer Service toll-free at (800) 985-5506, between 5:00 a.m. and 5:00 p.m., PST. Please tell us which model you purchased, the date of the purchase, and the problem with your Product. A copy of your original purchase receipt must accompany your service request.

### LIMITATION OF REMEDIES AND LIABILITY

Trinity (and its employees, officers, members, managers, affiliates and assigns) shall not be liable for any incidental, consequential, special, indirect, remote, special or punitive damages for breach of any warranty, express or implied, including, but not limited to, lost profits, lost savings, loss of anticipated benefits and attorneys' fees, which arise out of the purchase, use or inability to use the Product, whether arising out of contract, negligence, strict tort, product liability, or any other legal theory on which a claim is based. As noted above, to the extent damages are allowed by our express warranty or by applicable law, those damages may not exceed the purchase price paid for the Product. Without limiting the foregoing Purchaser assumes all risk and liability for loss, damage or injury to Purchaser and Purchaser's property and to others and their property arising out of the use, misuse, or inability to use this Product. This limited warranty shall not extend to anyone other than the original purchaser of this product, is nontransferable and states your exclusive remedy.

Some states do not allow the exclusion or limitation of incidental, consequential, special, or punitive damages, so the above limitation or exclusion may not apply to you. The above warranty gives you specific legal rights, and you may have other rights which vary from state to state.

---

## CONTACT US

**QUESTIONS? NEED PARTS?  
WE ARE HERE TO HELP!**

**Please feel free to contact us. There are no questions too small, or any problems too big. We're committed to providing our customers with the highest level of service.**

### **TRINITY Customer Service**

**TEL: 800.985.5506**

**FAX: 310.347.4134**

**EMAIL: [customerservice@trinityii.com](mailto:customerservice@trinityii.com)**

**Monday through Friday  
5:00 AM – 5:00 PM (PST)**

**[www.trinityii.com](http://www.trinityii.com)**



## OWNER'S MANUAL

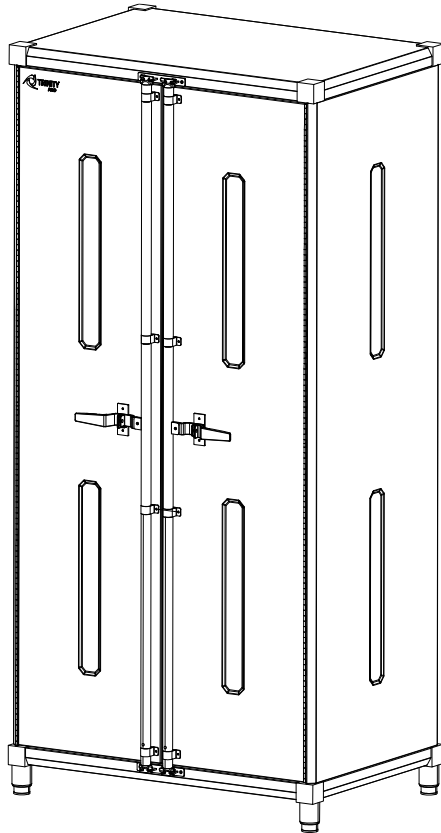

### TRINITY PRO 36" LOCKER CABINET Model # TSNPBK-0610



Important / Important / Importante

FOR QUICK & EASY 3D ASSEMBLY INSTRUCTIONS

POUR DES DIRECTIVES D'ASSEMBLAGE 3D RAPIDES ET FACILES

PARA INSTRUCCIONES DE ENSAMBLAJE RÁPIDAS Y SENCILLAS EN 3D

**BILT.**<sup>®</sup>

Intelligent Instructions  
Directives intelligentes  
Instrucciones Inteligentes



DOWNLOAD THE FREE APP | TÉLÉCHARGER L'APPLICATION GRATUITE | DESCARGUE LA APLICACIÓN GRATUITA



## PARTS LIST

Your TRINITY PRO 36" Locker Cabinet should include the following parts. Please inspect box contents to ensure you have received all components.

If you are missing any parts, need assistance with assembly or have questions, please contact TRINITY Customer Service: 800.985.5506 or [customerservice@trinityii.com](mailto:customerservice@trinityii.com). Parts can also be requested online via "Contact Us" section at [www.trinityii.com](http://www.trinityii.com).

No tools required for assembly.

A

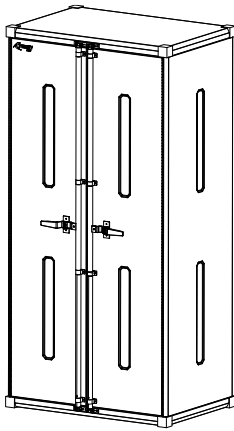

**CABINET BODY (1)**

B

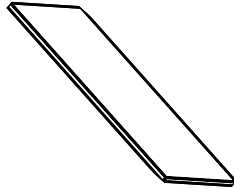

**SHELF (3)**

C



**SHELF SUPPORT (12)**

D

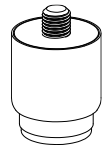

**FEET LEVELER (4)**

# ASSEMBLY INSTRUCTIONS

## STEP 1

Lay CABINET BODY (A) gently on its back. Two people are needed, do NOT attempt this alone.

Screw FEET LEVELER (D) fully into each pre-installed nut on four corners of cabinet bottom.

Stand cabinet right side up. Move it to desired location. Adjust FEET LEVELER (D) as needed to ensure your cabinet is level and stable.

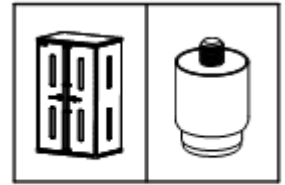

A (1)

D (4)

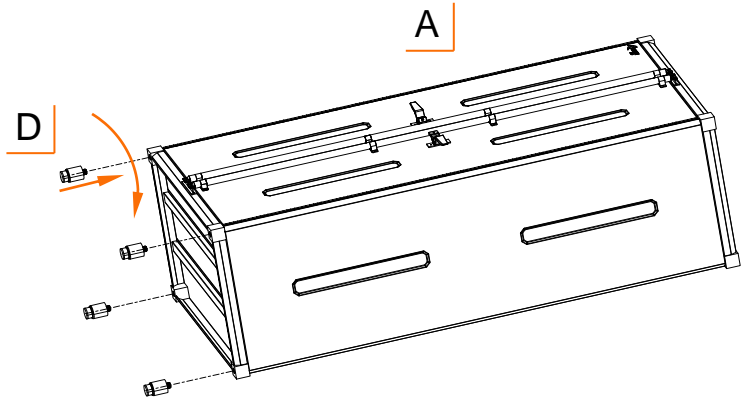

## STEP 2

Attach SHELF SUPPORT (C) by hooking it over position tab at desired height. Make sure all four SHELF SUPPORTS (C) are at same level.

Tilt SHELF (B) diagonally to move it inside cabinet. Place SHELF (B) on top of all four SHELF SUPPORTS (C).

Repeat above to install remaining shelves.

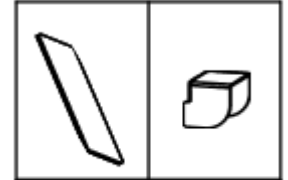

B (3)

C (12)

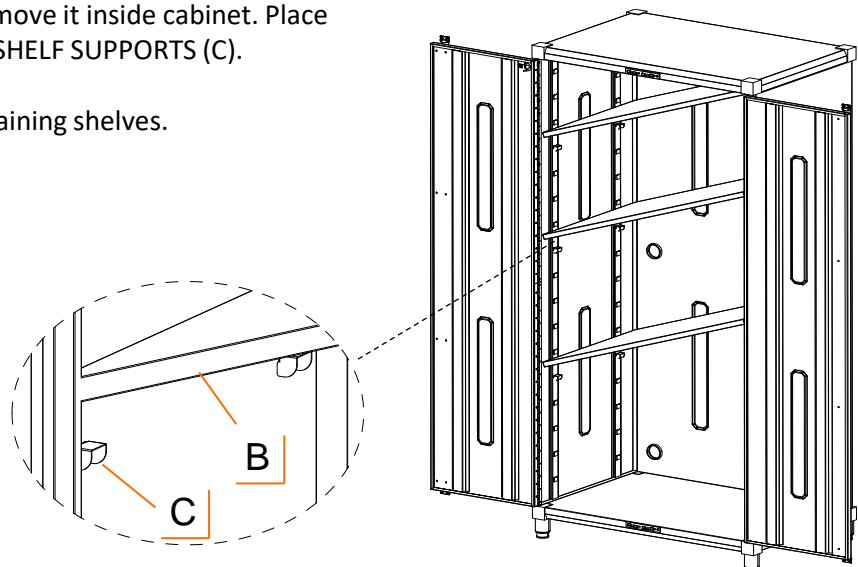



# USAGE INSTRUCTIONS

## OPEN AND CLOSE DOOR

Lift up door handle to release it from slot on handle base plate, rotate it forward and pull it to open door.

Close door by making sure ends of door bar is pushed against the stopper plate both on top and bottom. Rotate the door handle against door and slide into the slot on door handle base plate to keep door closed.

**Note:** To lock the door you need to buy a padlock with shackle diameter no larger than 9/32" (7mm). Put the shackle through the holes on door handle and handle base plate to lock the door.

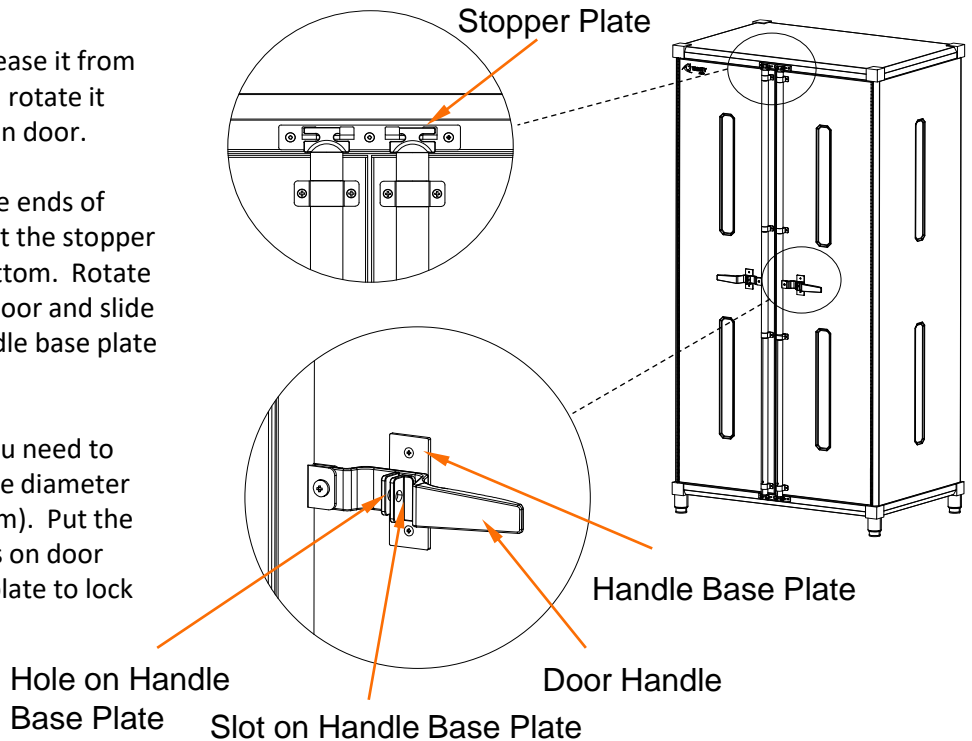

## SHELF ADJUSTMENT

Ensure all items have been removed from shelf.

To adjust shelf height position, take shelf out of cabinet, re-attach shelf supports to position tabs at desired height.

Tilt shelf diagonally to move it inside cabinet. Place shelf on top of all shelf supports.

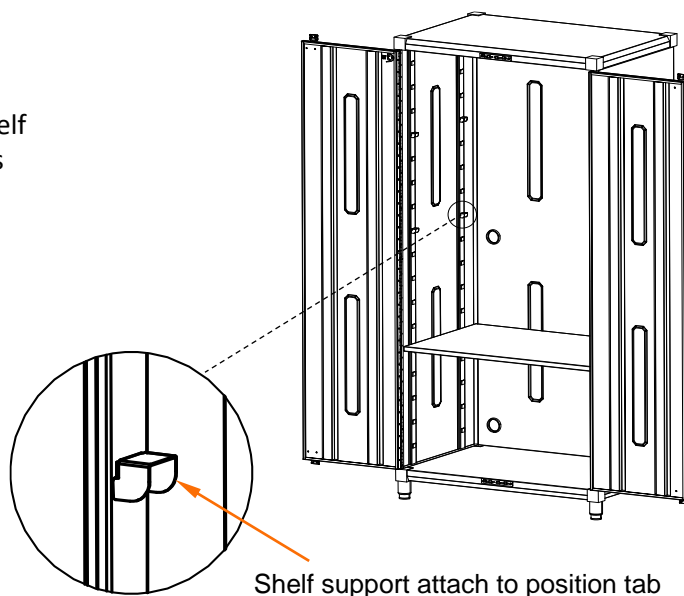

# SERVICE PARTS LIST – TSNPBK-0610

TRINITY Customer Service provides the following replacement parts:

Part Number	Description	Part Number	Description
1) PBK-18-020-3624	Cabinet Body	9) XSV-02-017-0001	Shelf Support
2) XSV-09-009-0004	Door Hinge	10) XSV-01-010-0616	Handle Screw
3) XBS-02-030-0002	Right Handle Base Plate	11) XBS-02-030-0001	Left Handle Base Plate
4) XBS-05-025-0720	Handle	12) XSV-01-010-0408	Door Bar Bracket Screw
5) XBS-02-029-0001	Door Bar Bracket	13) XBK-02-028-0001	Plastic Spacer
6) XBS-05-026-7075	Door Bar	14) XBS-02-027-0001	Door Bar Stopper
7) XBS-98-012-1662	Feet Leveler	15) XSV-01-027-0408	Stopper Screw
8) PBK-03-073-2235	Shelf		

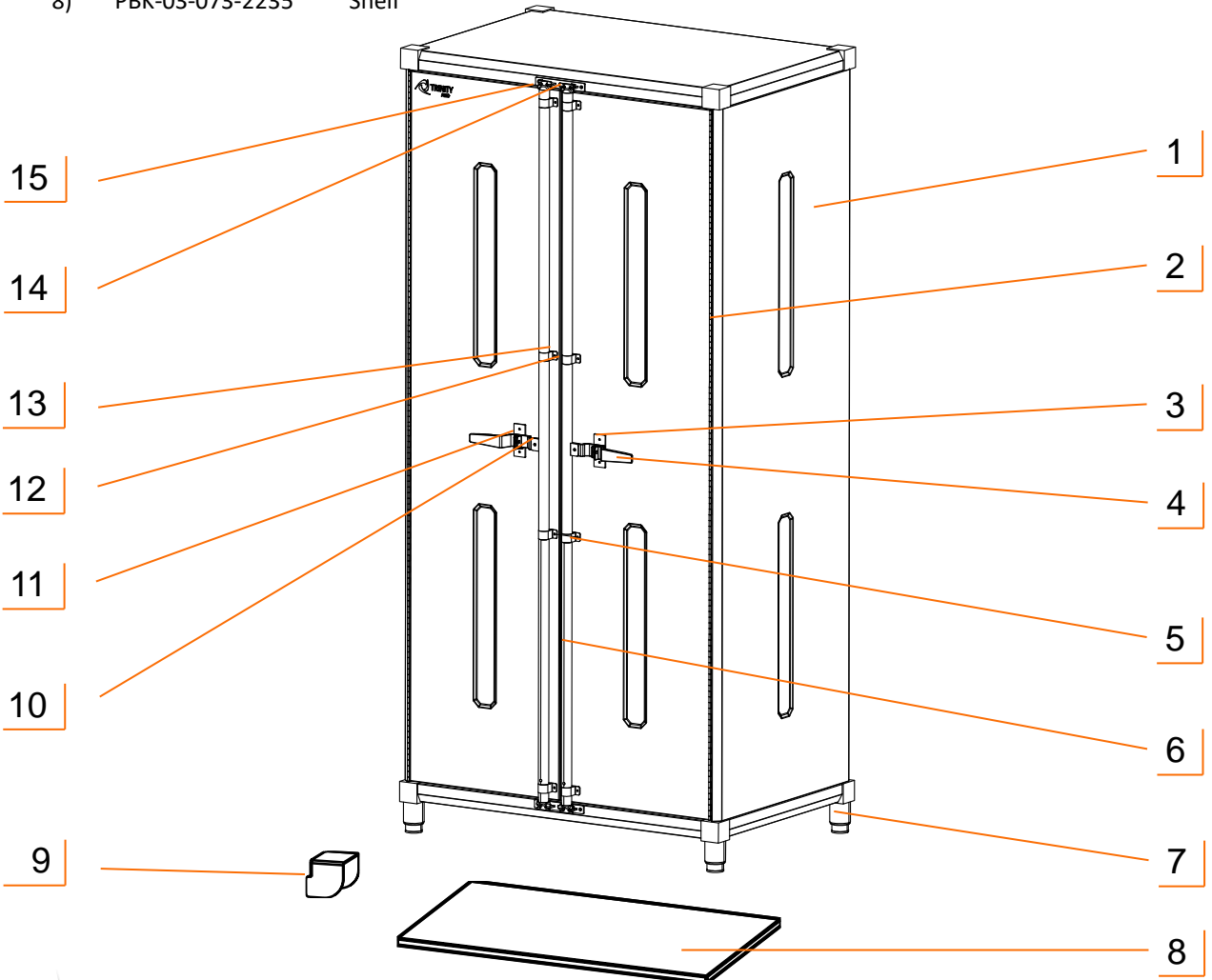

---

## WARNINGS

1. **Read and understand all instructions.** Failure to follow all instructions may result in injury and/or damage.
2. **The warnings, cautions, and instructions discussed in this manual cannot cover all possible conditions or situations that may occur.** The user must always be aware of their environment and ensure that they use the product in a safe and responsible manner.
3. **Do NOT modify the product in any way.** Unauthorized modification may impair the function and/or safety of the product, and may affect the life of the product. Any modifications will void warranty.
4. **Check for damaged parts.** Before using this product, carefully check that all parts are in good condition, and that the product will operate properly and perform its intended function. Check for damaged parts and any other conditions that may affect the operation of this product. Replace damaged or worn parts, and never use this product with a damaged part.
5. **Do NOT overload the product.**

Weight capacity per shelf (evenly distributed)	200 lb
Total weight capacity of cabinet (evenly distributed)	1000 lb

---

## CARE AND MAINTENANCE

- Avoid harsh, abrasive cleaners, and other corrosive chemicals.
- Do not use scouring pad for cleaning.
- This item is not certified for outdoor use.







---

# 1 YEAR LIMITED WARRANTY

## TRINITY PRO 36" Locker Cabinet Model # TSNPBK-0610

Trinity International Industries ("Trinity") warrants to the original consumer purchaser ("Purchaser") of the TRINITY PRO 36" Locker Cabinet ("Product") that each Product shall be free from defects in workmanship and materials for a period of 1 year from the date of original purchase. Trinity's obligation under this warranty shall be limited to repair or replacement of, or adequate compensation for the Product which shall not be greater than the amount of the purchase price of the Product, at the option of Trinity, during the warranty period. All replaced parts and Products become the property of Trinity and must be returned to Trinity.

This warranty excludes normal wear and tear of the Product and its parts or components, and damage arising from any of the following: negligent use or misuse of the Product, use contrary to this User's Manual, or alteration by any one other than Trinity. The warranty period of 1 year shall not be extended or renewed by the repair or replacement of, or compensation for, the Product. Any warranty implied by applicable law is limited in duration to one year from the date of purchase and is subject to the same conditions and limitations as is provided for our express warranty.

Except as set forth herein, and to the extent of applicable there are no warranties on this Product either express or implied, and Trinity disclaims all warranties including, but not limited to, any implied warranties of merchantability, infringement or fitness for a particular purpose. No warranty or guarantee given by any person, firm, or corporation with respect to this product shall be binding on Trinity.

If your Product is defective or otherwise requires service or parts, please call TRINITY Customer Service toll-free at (800) 985-5506, between 5:00 a.m. and 5:00 p.m., PST. Please tell us which model you purchased, the date of the purchase, and the problem with your Product. A copy of your original purchase receipt must accompany your service request.

### LIMITATION OF REMEDIES AND LIABILITY

Trinity (and its employees, officers, members, managers, affiliates and assigns) shall not be liable for any incidental, consequential, special, indirect, remote, special or punitive damages for breach of any warranty, express or implied, including, but not limited to, lost profits, lost savings, loss of anticipated benefits and attorneys' fees, which arise out of the purchase, use or inability to use the Product, whether arising out of contract, negligence, strict tort, product liability, or any other legal theory on which a claim is based. As noted above, to the extent damages are allowed by our express warranty or by applicable law, those damages may not exceed the purchase price paid for the Product. Without limiting the foregoing Purchaser assumes all risk and liability for loss, damage or injury to Purchaser and Purchaser's property and to others and their property arising out of the use, misuse, or inability to use this Product. This limited warranty shall not extend to anyone other than the original purchaser of this product, is nontransferable and states your exclusive remedy.

Some states do not allow the exclusion or limitation of incidental, consequential, special, or punitive damages, so the above limitation or exclusion may not apply to you. The above warranty gives you specific legal rights, and you may have other rights which vary from state to state.

---

## CONTACT US

**QUESTIONS? NEED PARTS?  
WE ARE HERE TO HELP!**

**Please feel free to contact us. There are no questions too small, or any problems too big. We're committed to providing our customers with the highest level of service.**

### **TRINITY Customer Service**

**TEL: 800.985.5506**

**FAX: 310.347.4134**

**EMAIL: [customerservice@trinityii.com](mailto:customerservice@trinityii.com)**

**Monday through Friday  
5:00 AM – 5:00 PM (PST)**

**[www.trinityii.com](http://www.trinityii.com)**





## OWNER'S MANUAL

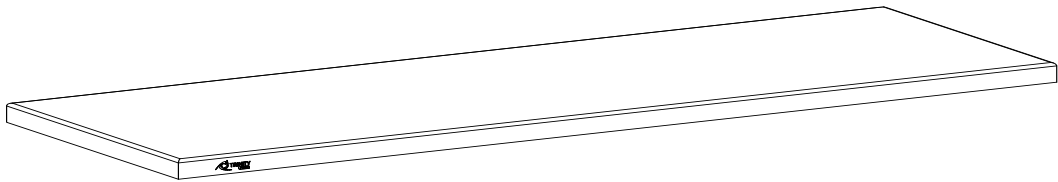

### TRINITY PRO 84" x 19" WOOD TOP Model # TSNLNA-7299



**Important / Important / Importante**



FOR QUICK & EASY 3D ASSEMBLY INSTRUCTIONS

POUR DES DIRECTIVES D'ASSEMBLAGE 3D RAPIDES ET FACILES

PARA INSTRUCCIONES DE ENSAMBLAJE RÁPIDAS Y SENCILLAS EN 3D

# **BILT.**<sup>®</sup>

Intelligent Instructions  
Directives intelligentes  
Instrucciones Inteligentes



## PARTS LIST

Your TRINITY PRO 84" x 19" Wood Top can be mounted on top of the TRINITY PRO Base Cabinet. To install it requires one of the following parts kit for assembly which are included in your TRINITY PRO Base Cabinet hardware package. Please inspect box contents to ensure you have received all components. You will also need a Phillips screwdriver for assembly which is not provided.

If you are missing any parts, need assistance with assembly or have questions, please contact TRINITY Customer Service: 800.985.5506 or [customerservice@trinityii.com](mailto:customerservice@trinityii.com). Parts can also be requested online via "Contact Us" section at [www.trinityii.com](http://www.trinityii.com).

### Hardware Parts (Included inside each Base Cabinet w/Doors Model # TSNPBK-0608)

A



**WOOD SCREW (8)**  
M4X16

B

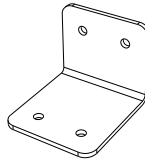

**WALL BRACKET (2)**

C

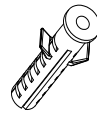

**WALL ANCHOR (4)**

D



**WALL SCREW (4)**  
M4X25

### Hardware Parts (Included inside each Base Cabinet w/Drawers Model # TSNPBK-0607)

A



**WOOD SCREW (4)**  
M4X16

# ASSEMBLY INSTRUCTIONS

## Option 1 (Installation across 2 Base Cabinets)

### Step 1

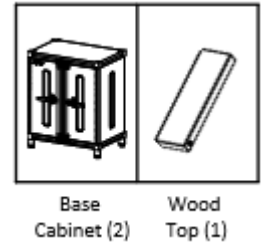

Move (2) assembled TRINITY PRO Base Cabinets to your desired location, and space them as shown below.

With 2 people, position a TRINITY PRO 84" x 19" WOOD TOP on the Base Cabinets, making sure that the ends are flush with the outside edge of each Base Cabinet.

Wood Top must be flush with the Base Cabinet edges to reach maximum weight capacity.

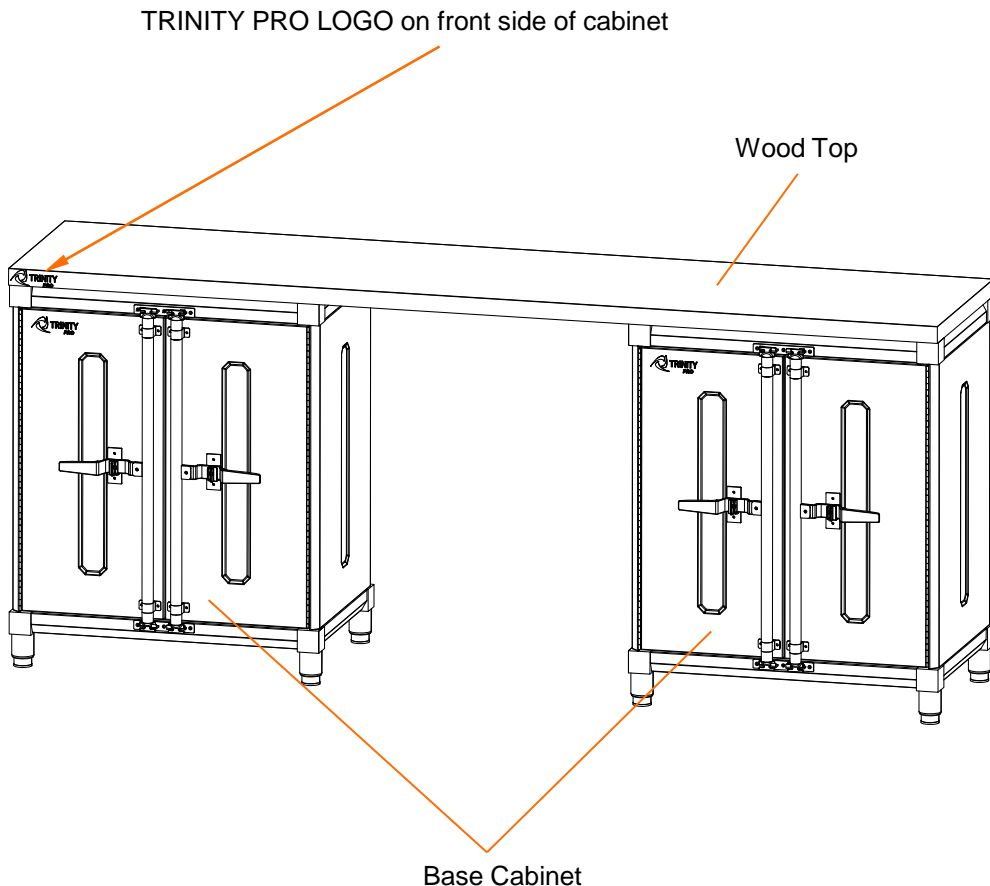

# ASSEMBLY INSTRUCTIONS

## Option 1 (Installation across 2 Base Cabinets)

### Step 2

Open doors of each Base Cabinet as shown below.

Insert WOOD SCREW (A) into each hole on base cabinet top and tighten them fully to wood top with an electric screwdriver (Phillips head).

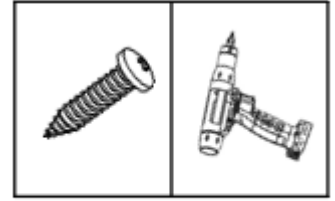

A (8)

Electric screwdriver  
(Phillips head)

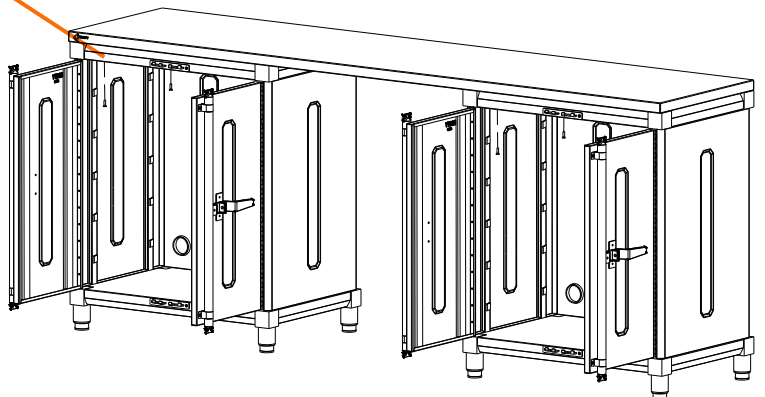
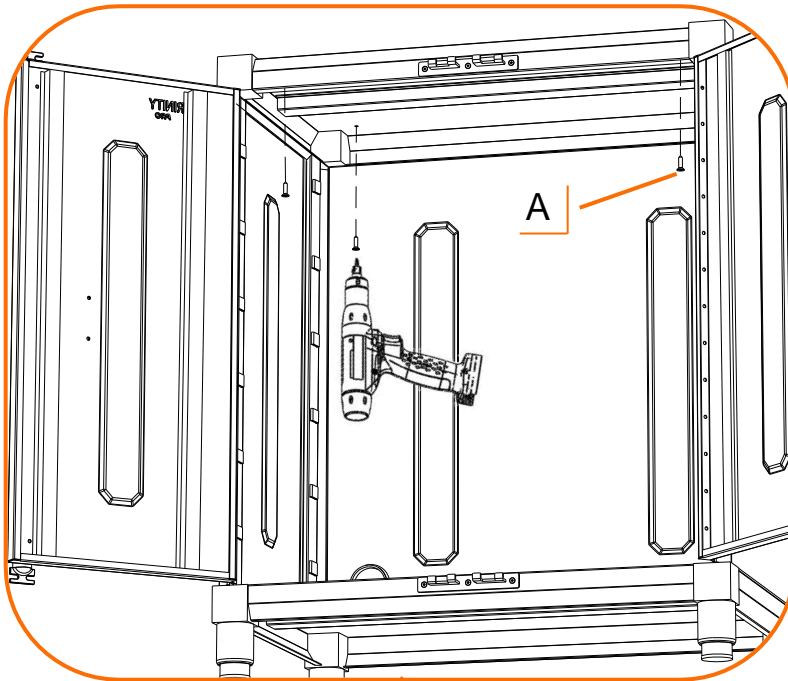

# ASSEMBLY INSTRUCTIONS

## Option 2 (Installation with Wood Top Overhang)

### Step 1

If you want to attach your Wood Top with 2 Base Cabinets next to each other and have overhang of the Wood Top on either side, please follow the below instructions.

Move (2) assembled TRINITY PRO Base Cabinets to desired location against the wall, and space them as shown below.

With 2 people, position a TRINITY PRO 84"x 19" WOOD TOP on the Base Cabinets as shown below, making sure that the ends are flush with the outside edge of each Base Cabinet.

Wood Top must be flush with the Base Cabinet edges to reach maximum weight capacity.

**Note:** This Wood Top must be attached to a minimum of 2 Base Cabinets. This Wood Top CANNOT be used with only 1 Base Cabinet.

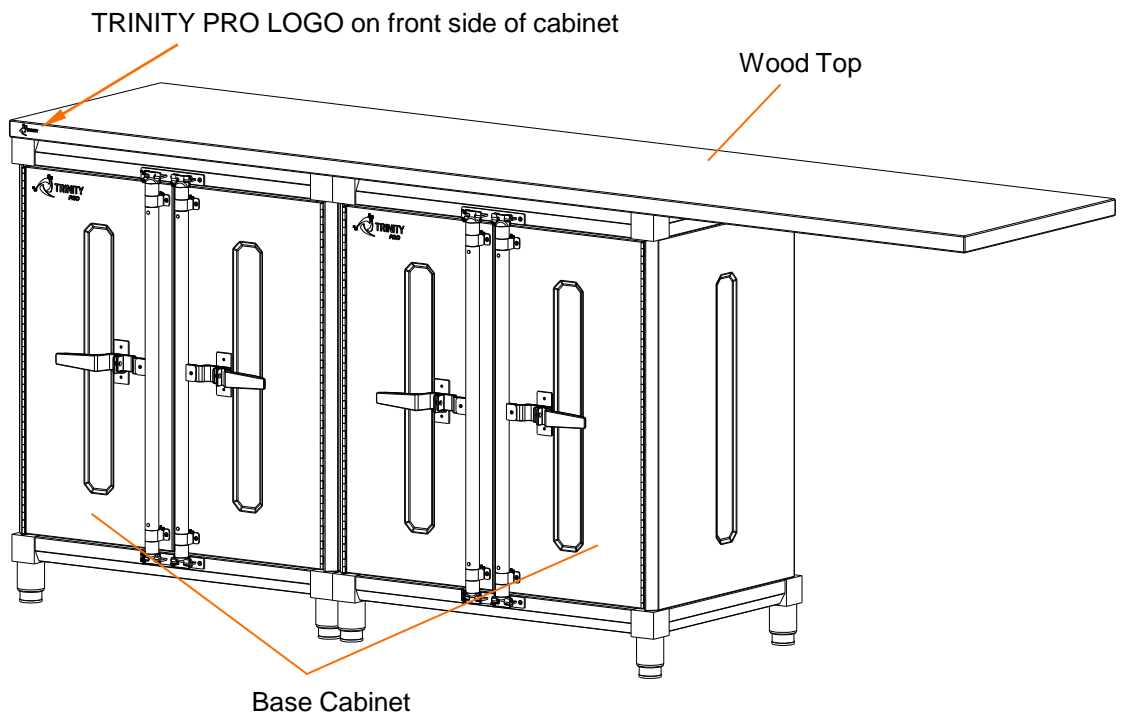
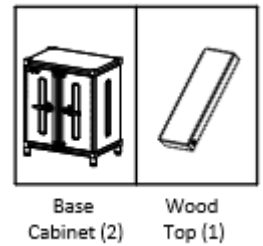

# ASSEMBLY INSTRUCTIONS

## Option 2 (Installation with Wood Top Overhang)

### Step 2

Open doors of each Base Cabinet as shown.

Insert WOOD SCREW (A) into each hole on base cabinet top and tighten them fully to wood top with an electric screwdriver (Phillips head).

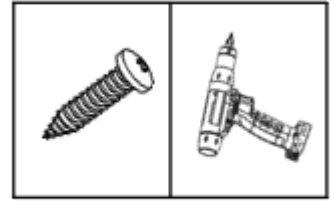

A (8)

Electric screwdriver  
(Phillips head)

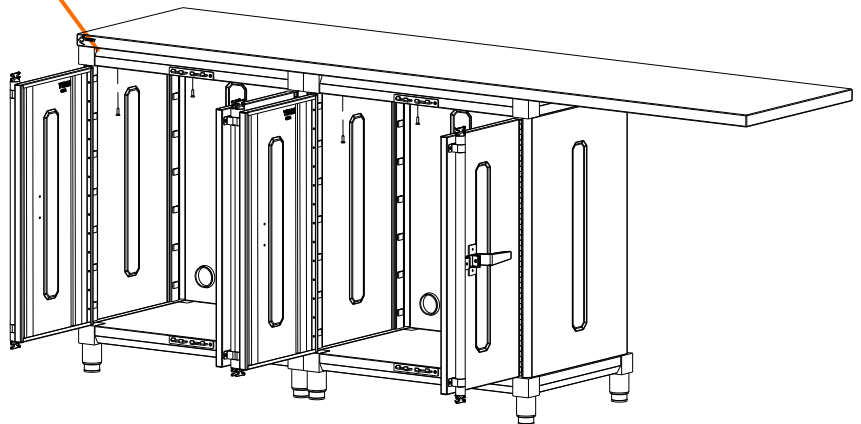
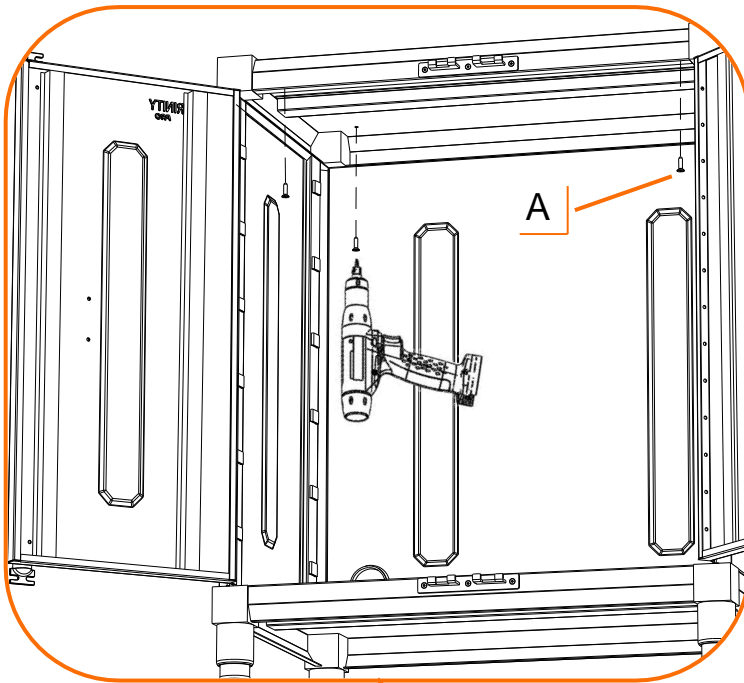

# ASSEMBLY INSTRUCTIONS

## Option 2 (Installation with Wood Top Overhang)

### Step 3

Place two WALL BRACKETS (B) to overhang Wood Top bottom as shown. Make sure that one side of WALL BRACKETS (B) attach to Wood Top bottom and the other side attach to wall. Make sure one bracket is as close as possible to end of unsupported end of wood top.

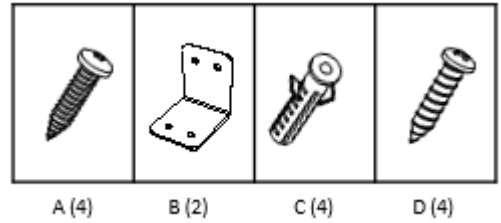

Mark off mounting location on wall through holes on WALL BRACKET (B). If WALL ANCHORS (C) are required, drill holes in marked locations. Insert WALL ANCHOR (C) completely into each drilled hole.

Insert WOOD SCREW (A) into holes on WALL BRACKET (B) and tighten them fully to Wood Top bottom with an electric screwdriver (Phillips head).

Fasten WALL SCREWS (D) through holes on WALL BRACKET (B) into the wall or anchors tightly with an electric screwdriver (Phillips head).

**Note:** Please consult a local contractor if you are unsure if your wall is able to bear the load of the Wood Top.

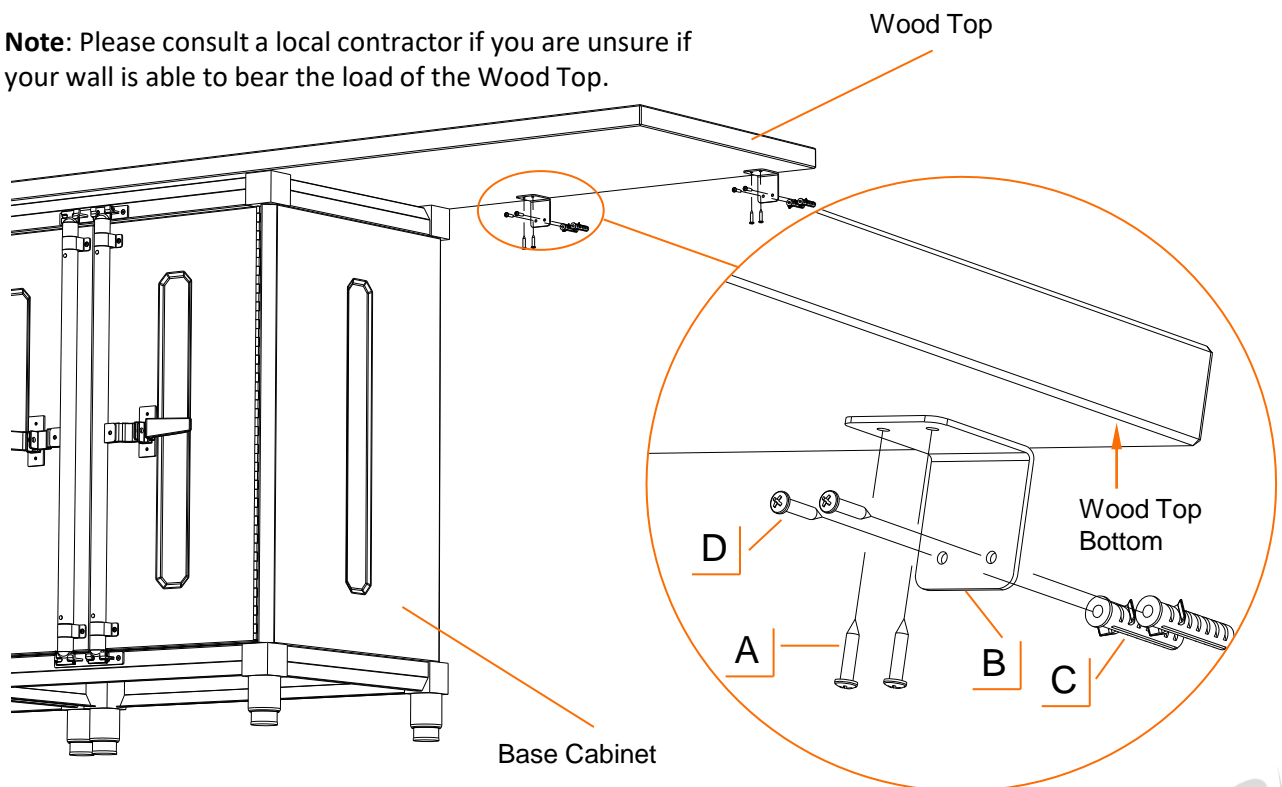

# ASSEMBLY INSTRUCTIONS

## Option 3 (Installation with 4 Base Cabinets)

### Step 1

Move (4) assembled TRINITY PRO Base Cabinets to your desired location, and space them as shown below.

With 2 people, position a TRINITY PRO 84"x 19" WOOD TOP on the Base Cabinets, making sure that the ends are flush with the outside edge of each Base Cabinet.

Wood Top must be flush with the Base Cabinet edges to reach maximum weight capacity.

**Note:** Base Cabinets can be oriented in any configuration, but this Wood Top must be attached to a minimum of 1 Base Cabinet + 1 Base Cabinet w/Drawers or 3 Base Cabinet with Drawers. This Wood Top CANNOT be used with only 1 Base Cabinet.

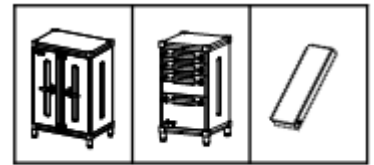

Base Cabinet w/Doors (1)    Base Cabinet w/Drawers (3)    Wood Top (1)

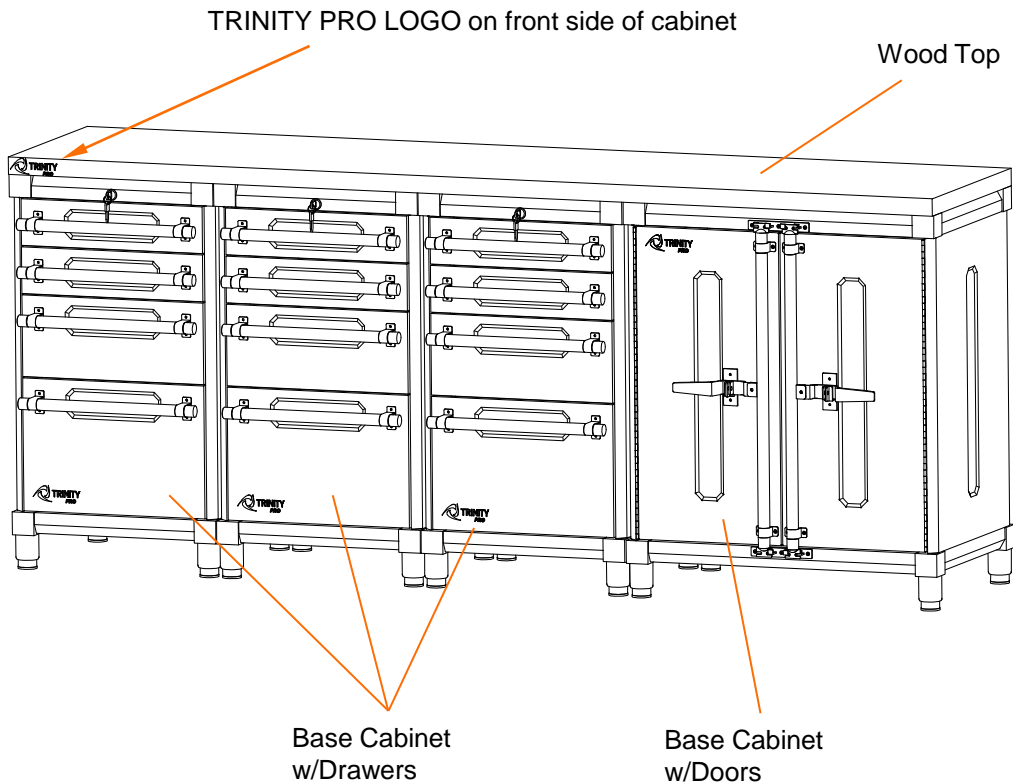



# ASSEMBLY INSTRUCTIONS

## Option 3 (Installation with 4 Base Cabinets)

### Step 2

Remove top three drawers of each Base Cabinet as shown below.

Open doors of Base Cabinet as shown below.

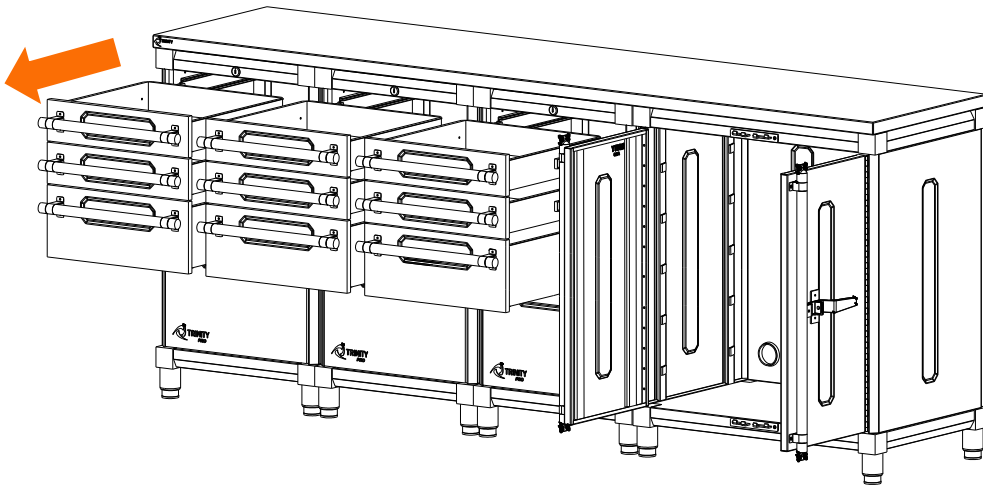

**DRAWER REMOVAL:** Pull drawer out so that it is almost fully extended. On RIGHT side, push black release lever DOWN. On LEFT side, pull black release lever UP. While holding levers as instructed, pull drawer forward until released from slides attached to Cabinet (“Cabinet Slides”).

**Note:** Slides attached to drawer (“Drawer Slides”) are an integral part of drawer and must be removed along with drawer itself.

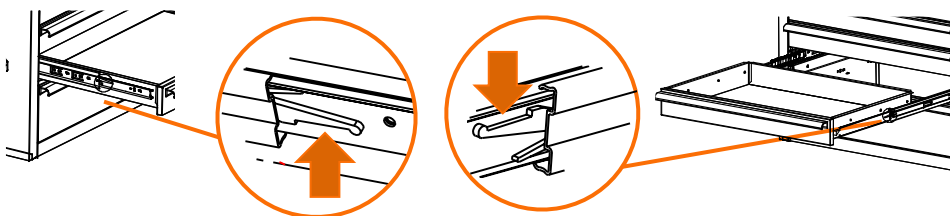

# ASSEMBLY INSTRUCTIONS

## Option 3 (Installation with 4 Base Cabinets)

### Step 3

Insert WOOD SCREW (A) into each hole on base cabinet top and tighten them fully to wood top with an electric screwdriver (Phillips head).

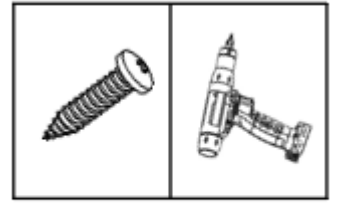

A (16)

Electric screwdriver  
(Phillips head)

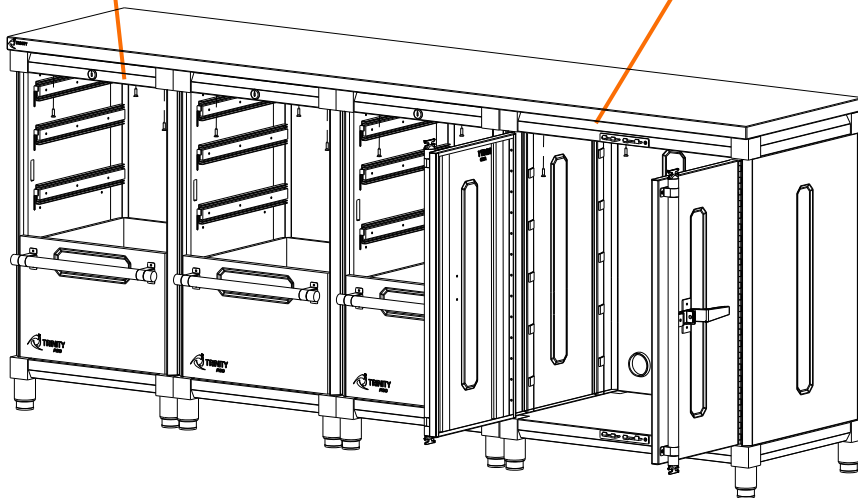
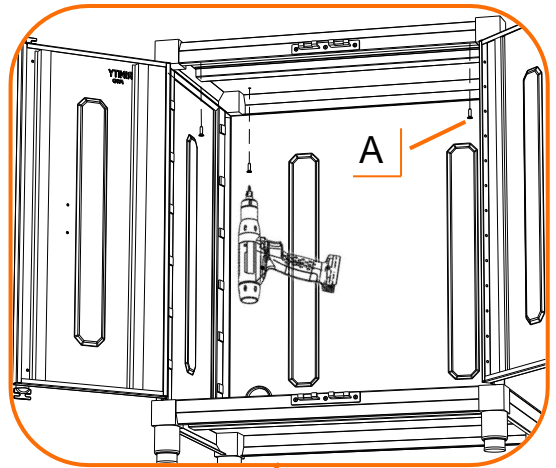
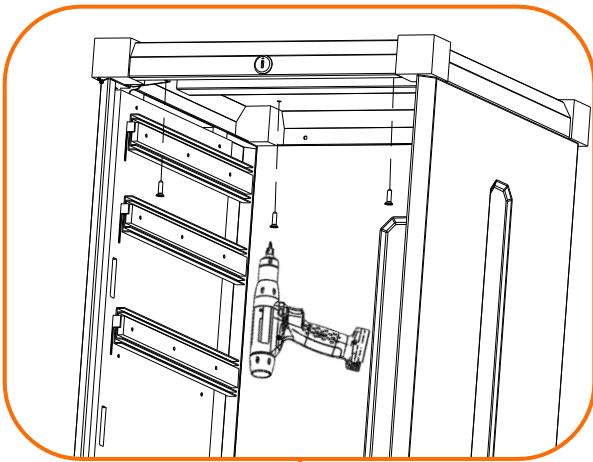

# ASSEMBLY INSTRUCTIONS

## Option 3 (Installation with 4 Base Cabinets) Step 4

**DRAWER REPLACEMENT :** To replace drawer, pull slides out completely. Insert brackets on each side of Drawer Slides into corresponding slots on Cabinet Slides, making sure they are properly positioned. Once brackets are inserted into slots, completely close drawer to set all slides in their proper positions.

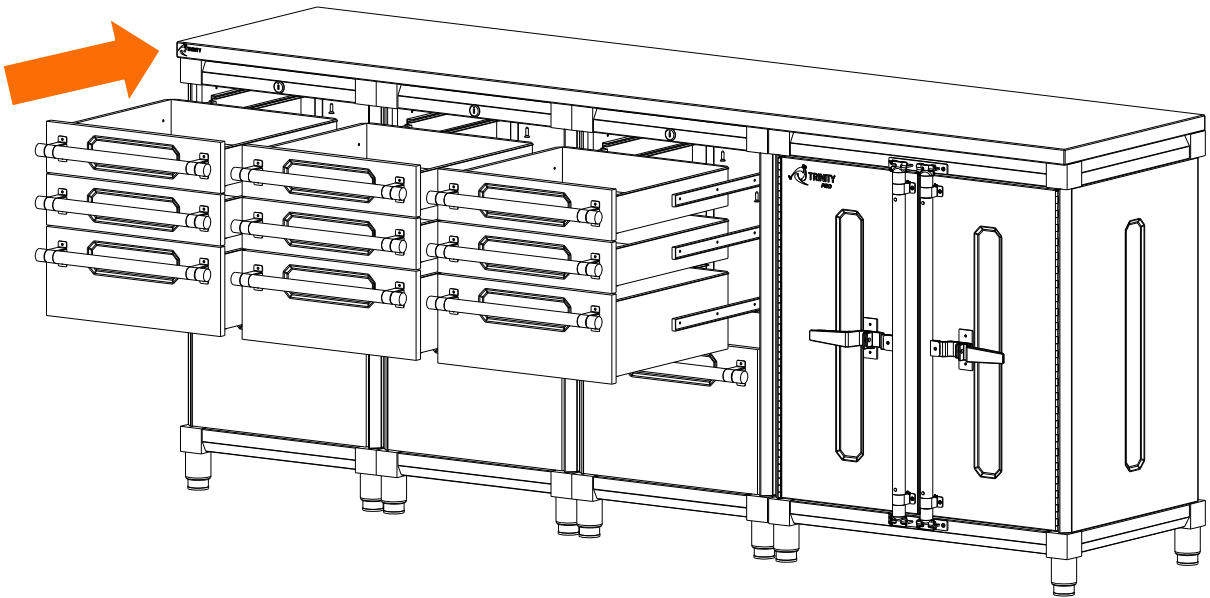

## SERVICE PARTS LIST

TRINITY Customer Service provides the following replacement parts:

	Part Number	Description
1)	PBK-02-011-0020	Wood Top Mounting Hardware Kit

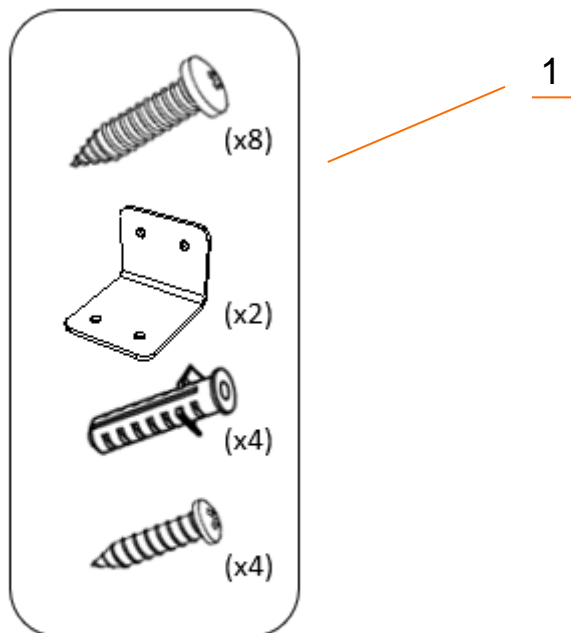

## WARNINGS

1. **Read and understand all instructions.** Failure to follow all instructions may result in injury and/or damage.
2. **The warnings, cautions, and instructions discussed in this manual cannot cover all possible conditions or situations that may occur.** The user must always be aware of their environment and ensure that they use the product in a safe and responsible manner.
3. **Do NOT modify the product in any way.** Unauthorized modification may impair the function and/or safety of the product, and may affect the life of the product.
4. **Check for damaged parts.** Before using this product, carefully check that all parts are in good condition, and that the product will operate properly and perform its intended function. Check for damaged parts and any other conditions that may affect the operation of this product. Replace damaged or worn parts, and never use this product with a damaged part.
5. **Do NOT overload the product.** Below capacity is based on evenly distributed weight.

Weight capacity on wood top in Option 1 configuration	1000 lb
Weight capacity on wood top in Option 2 configuration	600 lb
Weight capacity on wood top in Option 3 configuration	1000 lb

6. **Do NOT allow children to climb or play around the product.** Tipping may occur cause injury.
7. **Do NOT use wood top unless it is securely attached.** All screws must be fastened tightly. Checking regularly to ensure the screws have not loosened during use of wood top.
8. **Do NOT lift cabinet assembly by wood top.**
9. **Wood Top MUST be attached to either 2 Base cabinet w/Doors or 3 Base Cabinet w/Drawers.** Failure to do so may result in tipover, damage, and/or injury.
10. **Wood Top is to be used with TRINITY PRO Base Cabinets.**

## CARE AND MAINTENANCE

- Avoid harsh, abrasive cleaners, and other corrosive chemicals.
- Do not use scouring pad for cleaning.
- Clean up any spills immediately to prevent stains from forming on the wood top.
- Wood top can be cleaned with damp cloth and wiped dry immediately with dry cloth. If needed, solvent-based wood furniture cleaner can be used.

# PRODUCT REGISTRATION

Thank you for purchasing a TRINITY PRO 84" x 19" Wood Top. In order to register your product and receive streamlined customer service, please fill out the following Product Registration Form and (1) fax the form to 310.347.4134 (2) complete the Product Registration Form online at [www.trinityii.com](http://www.trinityii.com) or (3) scan and email the form to [customerservice@trinityii.com](mailto:customerservice@trinityii.com). Include a copy of your original receipt with your submission.

First Name: \_\_\_\_\_ Last Name: \_\_\_\_\_

Address: \_\_\_\_\_

City: \_\_\_\_\_ State: \_\_\_\_\_ Zip Code: \_\_\_\_\_

Email Address: \_\_\_\_\_ Phone: \_\_\_\_\_

Product Model #: TSNLNA-7299 Purchase Date: \_\_\_\_ / \_\_\_\_ / \_\_\_\_

Location of Purchase: \_\_\_\_\_

Please rate the importance of each feature (1=least important; 10=most important)

Quality \_\_\_\_ Price \_\_\_\_ Size/Capacity \_\_\_\_ Appearance \_\_\_\_ Other \_\_\_\_

How did you hear about our product?

- Magazine Ad     Catalog     Salesperson     Word of Mouth  
 Internet     Store Display     Other

Marital Status:                       Single                       Married

Household Income:                 Below \$50,000     \$50,000-\$150,000     \$150,000+

Education:                           High School             College             Graduate School

Primary Residence:                 Own                       Rent

Comments/Suggestions:



# 1 YEAR LIMITED WARRANTY

## TRINITY PRO 84" x 19" Wood Top Model # TSNLNA-7299

Trinity International Industries ("Trinity") warrants to the original consumer purchaser ("Purchaser") of the TRINITY PRO 84" x 19" Wood Top ("Product") that each Product shall be free from defects in workmanship and materials for a period of 1 year from the date of original purchase. Trinity's obligation under this warranty shall be limited to repair or replacement of, or adequate compensation for the Product which shall not be greater than the amount of the purchase price of the Product, at the option of Trinity, during the warranty period. All replaced parts and Products become the property of Trinity and must be returned to Trinity.

This warranty excludes normal wear and tear of the Product and its parts or components, and damage arising from any of the following: negligent use or misuse of the Product, use contrary to this User's Manual, or alteration by any one other than Trinity. The warranty period of 1 year shall not be extended or renewed by the repair or replacement of, or compensation for, the Product. Any warranty implied by applicable law is limited in duration to one year from the date of purchase and is subject to the same conditions and limitations as is provided for our express warranty.

Except as set forth herein, and to the extent of applicable there are no warranties on this Product either express or implied, and Trinity disclaims all warranties including, but not limited to, any implied warranties of merchantability, infringement or fitness for a particular purpose. No warranty or guarantee given by any person, firm, or corporation with respect to this product shall be binding on Trinity.

If your Product is defective or otherwise requires service or parts, please call TRINITY Customer Service toll-free at (800) 985-5506, between 5:00 a.m. and 5:00 p.m., PST. Please tell us which model you purchased, the date of the purchase, and the problem with your Product. A copy of your original purchase receipt must accompany your service request.

## LIMITATION OF REMEDIES AND LIABILITY

Trinity (and its employees, officers, members, managers, affiliates and assigns) shall not be liable for any incidental, consequential, special, indirect, remote, special or punitive damages for breach of any warranty, express or implied, including, but not limited to, lost profits, lost savings, loss of anticipated benefits and attorneys' fees, which arise out of the purchase, use or inability to use the Product, whether arising out of contract, negligence, strict tort, product liability, or any other legal theory on which a claim is based. As noted above, to the extent damages are allowed by our express warranty or by applicable law, those damages may not exceed the purchase price paid for the Product. Without limiting the foregoing Purchaser assumes all risk and liability for loss, damage or injury to Purchaser and Purchaser's property and to others and their property arising out of the use, misuse, or inability to use this Product. This limited warranty shall not extend to anyone other than the original purchaser of this product, is nontransferable and states your exclusive remedy.

Some states do not allow the exclusion or limitation of incidental, consequential, special, or punitive damages, so the above limitation or exclusion may not apply to you. The above warranty gives you specific legal rights, and you may have other rights which vary from state to state.

---

## CONTACT US

**QUESTIONS? NEED PARTS?  
WE ARE HERE TO HELP!**

**Please feel free to contact us. There are no questions too small, or any problems too big. We're committed to providing our customers with the highest level of service.**

### **TRINITY Customer Service**

**TEL: 800.985.5506**

**FAX: 310.347.4134**

**EMAIL: [customerservice@trinityii.com](mailto:customerservice@trinityii.com)**

**Monday through Friday  
5:00 AM – 5:00 PM (PST)**

**[www.trinityii.com](http://www.trinityii.com)**