

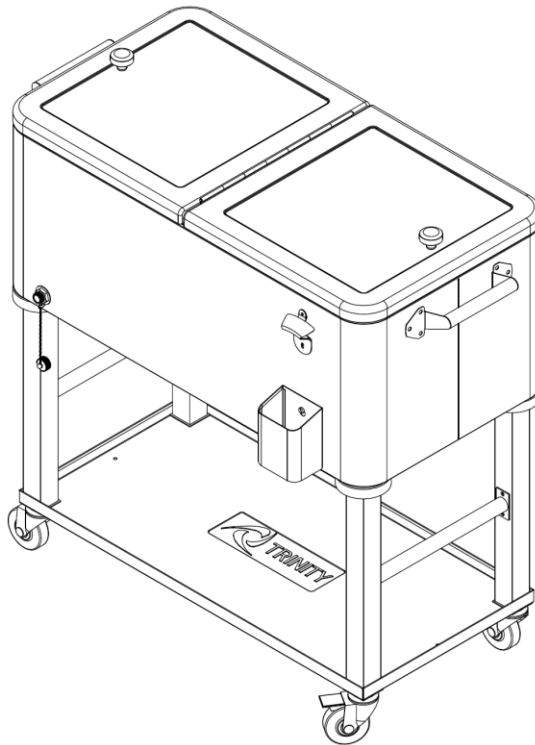

OWNER'S MANUAL



TRINITY 80 QT DETACHABLE STAINLESS STEEL COOLER W/ SHELF Model # TXK-0803



Important / Important / Importante

FOR QUICK & EASY 3D ASSEMBLY INSTRUCTIONS

POUR DES DIRECTIVES D'ASSEMBLAGE 3D RAPIDES ET FACILES

PARA INSTRUCCIONES DE ENSAMBLAJE RÁPIDAS Y SENCILLAS EN 3D

BILT.[®]

Intelligent Instructions
Directives intelligentes
Instrucciones Inteligentes





PARTS LIST

Your TRINITY Stainless Steel Cooler should include the following parts. Please inspect box contents to ensure you have received all components.

If you are missing any parts, need assistance with assembly or have questions, please contact TRINITY Customer Service: 800.985.5506 or customerservice@trinityii.com. Parts can also be requested online via "Contact Us" section at www.trinityii.com.

A

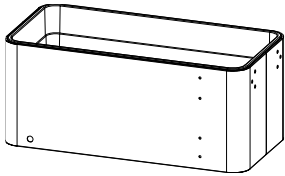

TUB (1)

B

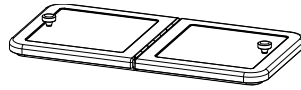

LID (1)

C

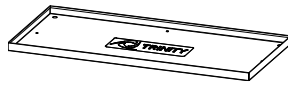

SHELF (1)

D

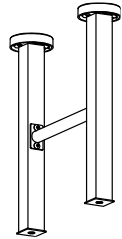

FRAME (2)

E

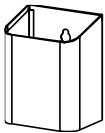

CAP CATCHER (1)

F



**LOCKING
CASTER (2)**

G



**NON-LOCKING
CASTER (2)**

H

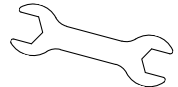

WRENCH (1)

ASSEMBLY INSTRUCTIONS

STEP 1

Place FRAMES (D) upside down so that black circular receivers are on the floor and approximately SHELF (C) width apart.

Align holes in SHELF (C) with bottom of FRAME (D), making sure that SHELF Lip is facing downwards.

Screw LOCKING CASTERS (F) into bottom of FRAMES (D), securing SHELF (C) in-between. Make sure LOCKING CASTERS (F) are installed on the same side.

Screw NON-LOCKING CASTERS (G) into bottom of FRAME (D), securing SHELF (C) in-between. Tighten all CASTERS (F, G) with provided WRENCH (H).

Use provided caster wrench to tighten completely. Failure to do as instructed could result in caster stem breaking.

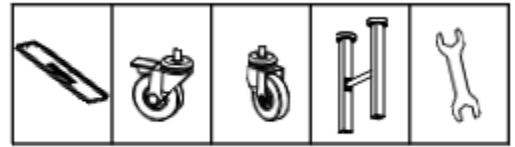

C (1) F (2) G (2) D (2) H (1)

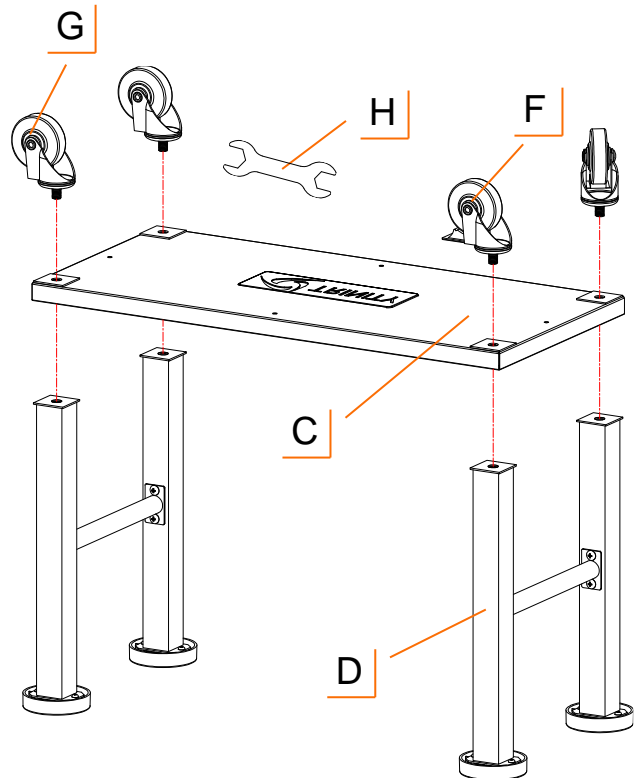

STEP 2

Attach CAP CATCHER (E) to TUB (A) by sliding it downward, over the metal notch.

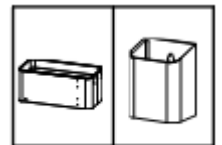

A (1) E (1)

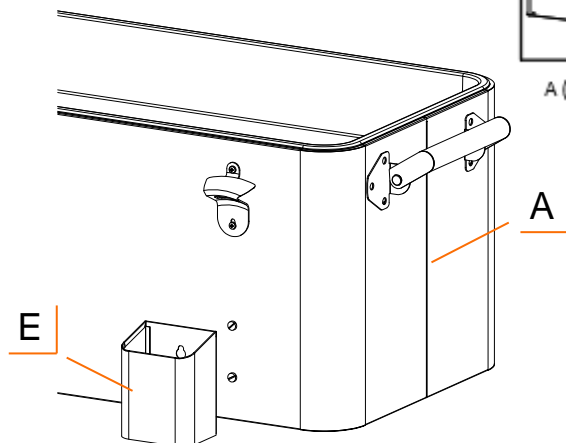

ASSEMBLY INSTRUCTIONS

STEP 3

Carefully turn cart right side up. Set TUB (A) on top of Cart. Make sure Tub Feet sit securely inside receivers on top of FRAME (D).

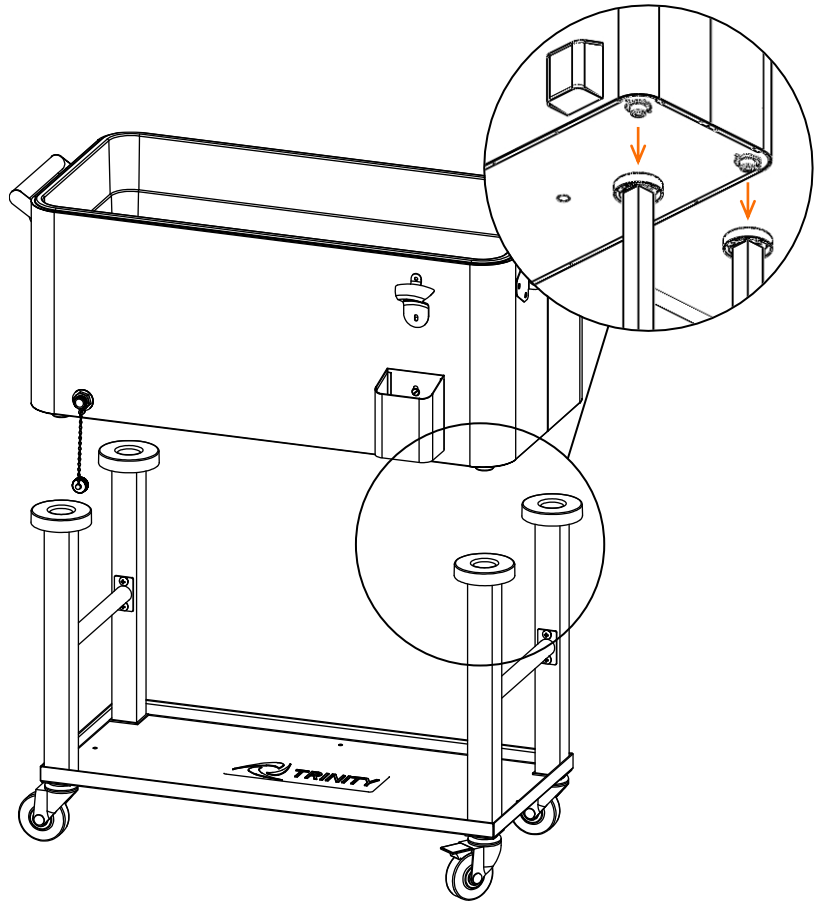

STEP 4

Set LID (B) on top of TUB (A).

Clean the inside of Cooler thoroughly before using.

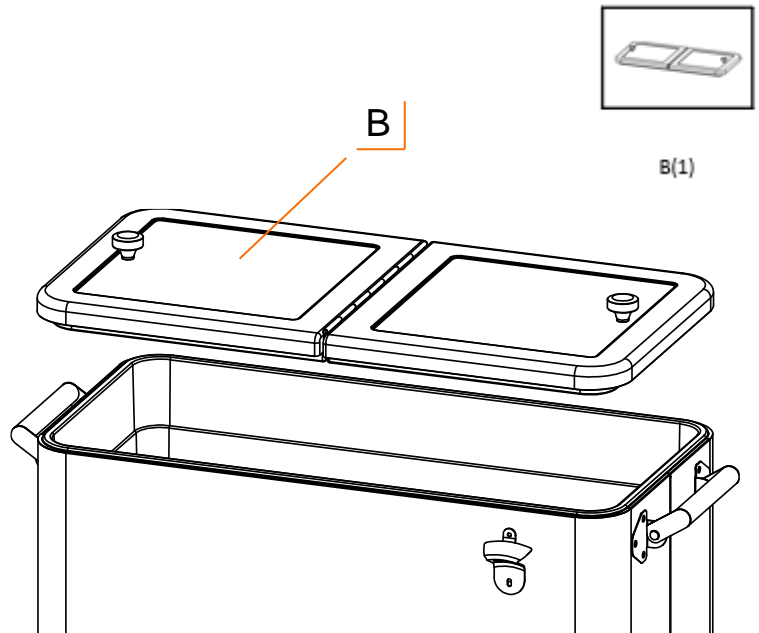

SERVICE PARTS LIST – TXK-0803

TRINITY Customer Service provides the following replacement parts:

Part Number	Description	Part Number	Description
1) PBR-17-002-3115	Cooler Lid	10) ZSV-99-011-3010	Non-Locking Caster
2) AMA-05-005-0150	Lib Knob	11) XXX-97-002-0007	Wrench
3) XSV-01-010-0530	Knob Screw	12) PBR-03-028-2913	Shelf
4) XST-02-004-0001	Bottle Opener	13) PBR-14-015-1517	Frame
5) XSV-01-010-0416	Small Screw	14) XSV-01-033-0415	Receiver Screw
6) XST-02-005-0002	Cap Catcher	15) CGL-02-003-0001	Drain Plug
7) XBK-98-009-4818	Tub Foot	16) XST-18-015-3115	Cooler Tub
8) XBK-02-019-0001	Plastic Receiver	17) XSV-05-023-0675	Folding Handle
9) ZSV-99-012-3010	Locking Caster	18) XSV-01-010-0615	Large Screw

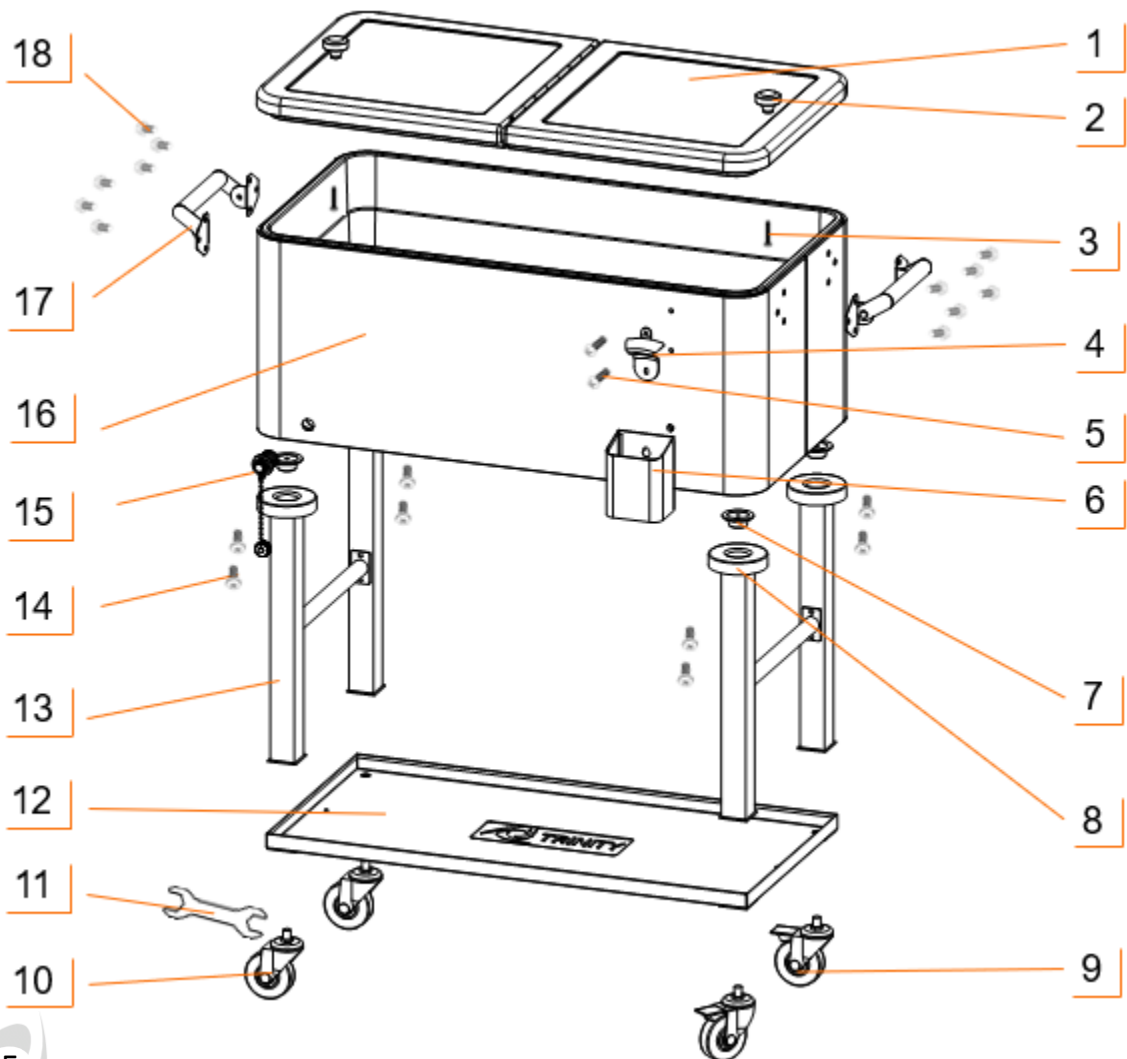

WARNINGS

1. **Read and understand all instructions.** Failure to follow all instructions may result in injury and/or damage.
2. **The warnings, cautions, and instructions discussed in this manual cannot cover all possible conditions or situations that may occur.** The user must always be aware of their environment and ensure that they use the product in a safe and responsible manner.
3. **Use the provided caster wrench to tighten completely.** Failure to do as instructed could result in the caster stem breaking thereby causing the cooler to collapse.
4. **Do NOT modify the product in any way.** Unauthorized modification may impair the function and/or safety of the product, and may affect the life of the product. Any modifications will void product warranty.
5. **Check for damaged parts.** Before using this product, carefully check that all parts are in good condition, and that the product will operate properly and perform its intended function. Check for damaged parts and any other conditions that may affect the operation of this product. Replace damaged or worn parts, and never use this product with a damaged part.
6. **Lift cooler tub by side handles ONLY.**
7. **Do NOT let children climb or play in the tub or on the shelf.**
8. **Do NOT overload the product.**

Volume Capacity	20 gallons / 80 qt
Weight capacity per shelf (evenly distributed)	50 lb
Total weight capacity (evenly distributed)	200 lb

9. **Lock the casters when leaving cooler in stationary position.**
10. **Ensure cooler tub is securely fastened to the leg frames before moving the cooler cart.**
11. **Do NOT push cooler with cart on uneven surface.** Cooler tub may detach from the cart and casters may be loosened and damaged causing the cart to collapse.
12. **Wood and laminate flooring can be scratched or dented.** Ensure your flooring can bear the weight of loaded product before rolling loaded product across your flooring.

CARE AND MAINTENANCE

- Remember to drain remaining water and remove un-melted ice after use. Wipe dry for storage.
- Avoid harsh, abrasive cleaners, and other corrosive chemicals.
- Do not use scouring pad for cleaning.
- Keep dry and avoid damp environments.
- Use a quality stainless steel cleaner and follow instructions that come with the cleaner. Wipe ALONG the grain (NOT against).
- Cooler should not be left out unprotected in the elements. A protective Cooler Cover (UBK-24-001-3519) is available as an accessory through www.trinityii.com.



PRODUCT REGISTRATION

Thank you for purchasing a TRINITY Stainless Steel Cooler. In order to register your product and receive streamlined customer service, please fill out the following Product Registration Form and (1) fax the form to 310.347.4134 (2) complete the Product Registration Form online at www.trinityii.com or (3) scan and email the form to customerservice@trinityii.com. Include a copy of your original receipt with your submission.

First Name: _____ Last Name: _____

Address: _____

City: _____ State: _____ Zip Code: _____

Email Address: _____ Phone: _____

Product Model #: _____ TXK-0803 _____ Purchase Date: _____ / _____ / _____

Location of Purchase: _____

Please rate the importance of each feature (1=least important; 10=most important)

Quality _____ Price _____ Size/Capacity _____ Appearance _____ Other _____

How did you hear about our product?

- Magazine Ad Catalog Salesperson Word of Mouth
 Internet Store Display Other

Marital Status: Single Married

Household Income: Below \$50,000 \$50,000-\$150,000 \$150,000+

Education: High School College Graduate School

Primary Residence: Own Rent

Comments/Suggestions:





1 YEAR LIMITED WARRANTY

TRINITY Stainless Steel Cooler Model # TXK-0803

Trinity International Industries (“Trinity”) warrants to the original consumer purchaser (“Purchaser”) of the TRINITY Stainless Steel Cooler (“Product”) that each Product shall be free from defects in workmanship and materials for a period of 1 year from the date of original purchase. Trinity’s obligation under this warranty shall be limited to repair or replacement of, or adequate compensation for the Product which shall not be greater than the amount of the purchase price of the Product, at the option of Trinity, during the warranty period. All replaced parts and Products become the property of Trinity and must be returned to Trinity.

This warranty excludes normal wear and tear of the Product and its parts or components, and damage arising from any of the following: negligent use or misuse of the Product, use contrary to this User’s Manual, or alteration by any one other than Trinity. The warranty period of 1 year shall not be extended or renewed by the repair or replacement of, or compensation for, the Product. Any warranty implied by applicable law is limited in duration to one year from the date of purchase and is subject to the same conditions and limitations as is provided for our express warranty.

Except as set forth herein, and to the extent of applicable there are no warranties on this Product either express or implied, and Trinity disclaims all warranties including, but not limited to, any implied warranties of merchantability, infringement or fitness for a particular purpose. No warranty or guarantee given by any person, firm, or corporation with respect to this product shall be binding on Trinity.

If your Product is defective or otherwise requires service or parts, please call TRINITY Customer Service toll-free at (800) 985-5506, between 5:00 a.m. and 5:00 p.m., PST. Please tell us which model you purchased, the date of the purchase, and the problem with your Product. A copy of your original purchase receipt must accompany your service request.

LIMITATION OF REMEDIES AND LIABILITY

Trinity (and its employees, officers, members, managers, affiliates and assigns) shall not be liable for any incidental, consequential, special, indirect, remote, special or punitive damages for breach of any warranty, express or implied, including, but not limited to, lost profits, lost savings, loss of anticipated benefits and attorneys’ fees, which arise out of the purchase, use or inability to use the Product, whether arising out of contract, negligence, strict tort, product liability, or any other legal theory on which a claim is based. As noted above, to the extent damages are allowed by our express warranty or by applicable law, those damages may not exceed the purchase price paid for the Product. Without limiting the foregoing Purchaser assumes all risk and liability for loss, damage or injury to Purchaser and Purchaser’s property and to others and their property arising out of the use, misuse, or inability to use this Product. This limited warranty shall not extend to anyone other than the original purchaser of this product, is nontransferable and states your exclusive remedy.

Some states do not allow the exclusion or limitation of incidental, consequential, special, or punitive damages, so the above limitation or exclusion may not apply to you. The above warranty gives you specific legal rights, and you may have other rights which vary from state to state.

CONTACT US

**QUESTIONS? NEED PARTS?
WE ARE HERE TO HELP!**

Please feel free to contact us. There are no questions too small, or any problems too big. We're committed to providing our customers with the highest level of service.

TRINITY Customer Service

TEL: 800.985.5506

FAX: 310.347.4134

EMAIL: customerservice@trinityii.com

**Monday through Friday
5:00 AM – 5:00 PM (PST)**

www.trinityii.com